



ITT

Industrial Process

Installation, Operation, and Maintenance Manual

Bio-Pure



Engineered for life





Table of Contents

Introduction and Safety	2
Safety message levels.....	2
User health and safety.....	2
Transportation and storage	4
Handling and unpacking guidelines.....	4
Storage, disposal, and return requirements.....	4
Product Description	5
Bio-Pure identification.....	5
Bonnet description.....	6
Valve diaphragm identification.....	6
Installation	8
Install the valve and topworks.....	8
Mount the topworks to the valve.....	8
Tighten the bonnet fasteners.....	8
Fastener torque table for valve body to topworks.....	9
Operation	10
Actuator operating pressure.....	10
Maintenance	11
Precautions.....	11
Inspection.....	11
Disassemble the valve.....	12
Replace the valve diaphragm.....	12
Travel (closing) stop for manual valve.....	14
Adjust the travel (closing) stop with air pressure.....	14
Adjust the travel (closing) stop without air pressure.....	14
Lubrication requirements.....	14
Parts Listing and Cross-Sectional Drawings	16
Bio-Pure manual topworks.....	16
Bio-Pure COP manual topworks.....	17
Bio-Pure AXS actuator.....	18

Introduction and Safety

Safety message levels

Definitions

Safety message level	Indication
 <p>DANGER:</p>	A hazardous situation which, if not avoided, will result in death or serious injury
 <p>WARNING:</p>	A hazardous situation which, if not avoided, could result in death or serious injury
 <p>CAUTION:</p>	A hazardous situation which, if not avoided, could result in minor or moderate injury
 <p>Electrical Hazard:</p>	The possibility of electrical risks if instructions are not followed in a proper manner
NOTICE:	<ul style="list-style-type: none"> • A potential situation which, if not avoided, could result in an undesirable result or state • A practice not related to personal injury

User health and safety

General precautions

This product is designed and manufactured using good workmanship and materials, and meets all applicable industry standards. This product should be used only as recommended by an IIT engineer.



WARNING:

- Misapplication of the valve can result in injury or property damage. Select valves and valve components of the proper materials and make sure that they are consistent with your specific performance requirements. Incorrect application of this product includes but is not limited to:
 - Exceeding the pressure or temperature rating
 - Failing to maintain this product according to the recommendations
 - Using this product to handle caustic or hazardous substances that it is not designed to handle
- If the product exhibits any indication of leakage, do not operate. Isolate the product and either repair it or replace it as outlined within this manual.

Qualifications and training

The personnel responsible for the assembly, operation, inspection, and maintenance of the valve must be appropriately qualified. The operating company must do the following tasks:

- Define the responsibilities and competency of all personnel handling this equipment.
- Provide instruction and training.
- Ensure that the contents of the operating instructions have been fully understood by the personnel.

Instruction and training can be carried out by either IIT or the reseller of the valve by order of the operating company.

Non-compliance risks

Failure to comply with all safety precautions can result in the following conditions:

- Death or serious injury due to electrical, mechanical, and chemical influences
- Environmental damage due to the leakage of dangerous materials
- Product damage
- Property damage
- Loss of all claims for damages

Operational safety precautions

Be aware of these safety precautions when operating this product:

- Do not leave hot or cold components of the product unsecured against contact if they are a source of danger.
- Do not remove the contact guard for moving parts when the product is in operation. Never operate the product without the contact guard installed.
- Do not hang items from the product. Any accessories must be firmly or permanently attached.
- Do not use the product as a step or hand hold.
- Do not paint over the identification tag, warnings, notices, or other identification marks associated with the product.
- PTFE diaphragms emit toxic fumes due to thermal decomposition at temperatures of 716°F (380°C) or greater.

Maintenance safety precautions

Be aware of these safety precautions when performing maintenance on this product:

- You must decontaminate the product if it has been exposed to harmful substances such as caustic chemicals.
- You must immediately fit or reactivate all safety and protective equipment upon completion of work.
- Work on externally actuated valves should only be performed when the valve is removed from service.
- On completion of work, all safety and protective equipment must immediately be fitted again or reactivated.
- Before the re-operation, pay attention to the points in the following sections.

Use of unauthorized parts

Reconstruction or modification of the product is only permissible after consultation with IIT. Genuine spare parts and accessories authorized by IIT serve to maintain safety. Use of non-genuine IIT parts can annul liability of the manufacturer for the consequences. IIT parts are not to be used in conjunction with products not supplied by IIT as this improper use can annul all liability for the consequences.

The use of diaphragms other than genuine IIT diaphragms violates diaphragm valve industry standard MSS SP-88. Valve pressure, temperature, and overall performance can not be guaranteed.

Unacceptable modes of operation

The operational reliability of this product is only guaranteed when it is used as designated. The operating limits given on the identification tag and in the data sheet may not be exceeded under any circumstances. If the identification tag is missing or worn, contact IIT for specific instructions.

Transportation and storage

Handling and unpacking guidelines



CAUTION:

Always observe the applicable standards and regulations regarding the prevention of accidents when handling the product.

Handling guidelines

Follow these guidelines when handling the product to prevent damage:

- Use care when handling the product.
- Leave protective caps and covers on the product until installation.

Unpacking guidelines

Follow these guidelines when unpacking the product:

1. Inspect the package for damaged or missing items upon delivery.
2. Note any damaged or missing items on the receipt and freight bill.
3. If anything is out of order, file a claim with the shipping company.

Storage, disposal, and return requirements

Storage

If you are not immediately installing the product after delivery, store it as follows:

- Store the product in a dry room that maintains a constant temperature.
- Make sure that the products are not stacked on top of one another.

Disposal

Dispose of this product and associated components in compliance with federal, state, and local regulations.

Return

Ensure these requirements are met before you return a product to ITT:

- Contact ITT for specific instructions on how to return the product.
- Clean the valve of all hazardous material.
- Complete a Material Safety Data Sheet or Process Data Sheet for any process fluid that could remain on the valve.
- Obtain a Return Material Authorization from the factory.

Product Description

Bio-Pure identification

Model number

The Bio-Pure model numbers contains the following:

Table 1: Body type

Code	Description
BP	Forging

Table 2: Diaphragm type

Code	Description
17	EPDM
TM17	PTFE

Table 3: Manual topworks

Code	Description
BPM	Manual bonnet
BPMC	Manual bonnet sealed (COP)

Table 4: Actuated topworks

Code	Description
AXS29	Fail close 90# spring package
AXS26	Fail close 60# spring package
AXS1	Fail open
AXS3	Double acting

Table 5: Examples

Model number	Description
BP-TM17-BPM	Bio-Pure forging with a PTFE diaphragm and manual bonnet
BP-17-AXS29	Bio-Pure forging with a EPDM diaphragm and fail close 90# spring package

Identification tag

For actuated valves, the model number is located on the ITT identification tag.

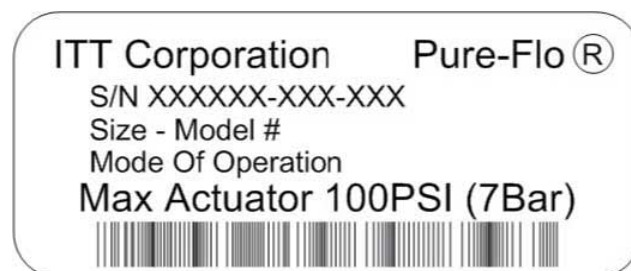

Figure 1

Line	Description
1	Valve serial number
2	Valve size and model number

Line	Description
3	Actuator mode of operation
4	Maximum recommended actuation pressure

Bonnet description

Manual and actuator bonnet

The manual bonnet and actuator bonnet are non-sealed and have a weep hole that permits leakage of the process fluid if the diaphragm ruptures.

Manual bonnet sealed (COP)

The manual bonnet sealed (COP) does not include a weep hole or V-notch vent plug. The COP manual topworks can only be cleaned (submerged) when the topworks is assembled to a valve body.

Valve diaphragm identification

Diaphragm tab codes

All diaphragm materials and physical properties are batch traceable via permanent codes molded into the diaphragm tabs. The molding date, grade of diaphragm, and valve size provide traceability to original batch records.



Figure 2: Elastomer diaphragm front



Figure 3: Elastomer diaphragm back

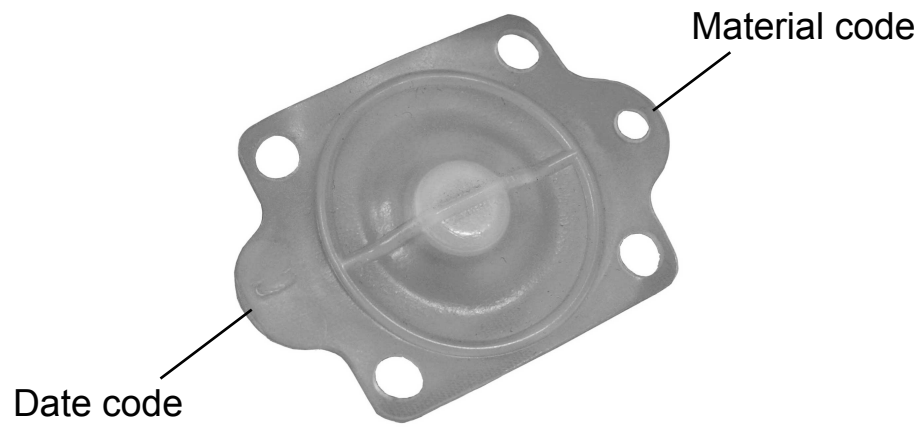

Figure 4: PTFE diaphragm

Installation

Install the valve and topworks

NOTICE:

The topworks size and configuration can limit the actual operating pressure. Consult the engineering catalog for topworks sizing. Consult the factory or engineering catalog for vacuum operation.

Consider the following information before installing the actuator:

- The maximum valve operating pressure is 150 psig (10.34 bar). This pressure is applicable up to 100° F (38° C). Valves at maximum pressure cannot be used at maximum temperatures.
 - The maximum actuator pressure is 100 psi (6.9 bar).
1. If you have a weld end valve, then consider the following:

If you are welding ...	Then ...
Manually	Remove the topworks.
In line	You can weld with automatic equipment. Before you perform the weld: <ol style="list-style-type: none"> 1. Do not remove the topworks. 2. Set the valve to the open position. 3. Properly purge the valve with an inert gas.

2. Install the valve.
3. Prior to pressurization (with the valve slightly open), tighten the bonnet fasteners.
For more information, see [Tighten the bonnet fasteners](#) (page 8).
4. If you have an actuated topworks, then connect the air line.
Connection size is 1/8" NPT.
5. Cycle the valve two to three times to verify smooth operation.

Mount the topworks to the valve

1. For actuated topworks, regulate the air pressure.

If the topworks is ...	Then regulate the air pressure ...
AXS1, AXS3	In the upper cover to extend the compressor.
AXS26, AXS29	In the lower cover to properly position the valve diaphragm.

2. Install the valve diaphragm.
For more information, see [Replace the valve diaphragm](#) (page 12).
3. Assemble the valve body and tighten the bonnet fasteners.
For more information, see [Tighten the bonnet fasteners](#) (page 8).
4. If there is a travel (closing) stop, reset it to ensure proper closure.
For more information, see Adjust the travel (closing) stop in this manual.

Tighten the bonnet fasteners



CAUTION:

Do not tighten fasteners while the system is pressurized or at elevated temperatures (greater than 100°F (38°C)).

1. Depressurize the system.
2. Position diaphragm so that valve is slightly open.

For valves with an actuator, you may need to use regulated air pressure to actuate the valve.

3. Tighten the bonnet fasteners in a crisscross pattern.
For more information, see [Fastener torque table for valve body to topworks](#) (page 9).
4. Make multiple crisscross passes to build up torque to the final table value. Make additional crisscross passes using final table values to evenly tighten each fastener to within 5% of torque value.
5. Retighten the bonnet fasteners as noted above at ambient conditions after the system has cycled through operating pressure and temperature.
6. Monitor the valve for leakage:

If leakage ...	Then ...
Occurs at the body/bonnet flange sealing area	Depressurize the system and retighten the bonnet fasteners as noted above.
Continues	Depressurize the system and retighten the bonnet fasteners as noted above. (maximum 3rd re-torque)
Continues	Replace the valve diaphragm.

For more information, see [Replace the valve diaphragm](#) (page 12).

Fastener torque table for valve body to topworks

Values given are for lubricated fasteners.

Valve size		Bolt size		PTFE diaphragm		Elastomer diaphragm	
Inch	DN	Imperial	Metric	in-lb	N-m	in-lb	N-m
Bio-Pure (0.25, 0.375, 0.50)	Bio-Pure (8, 10, 15)	Not available	M4	15-18	1.7-2.0	12-15	1.4-1.7

Guidelines

- Minimum values given will provide a longer diaphragm cycle life for valves in non-autoclave and low thermal cycle conditions.
- Maximum values given may be necessary for autoclave conditions and for high thermal cycle conditions.
- Torques should be applied at near ambient conditions (less than 100°F (38°C)).

Operation

Actuator operating pressure

Maximum permitted air supply pressure

psig	bar	kPA
100	6.9	690

Actuator pressure rating

The actuator will withstand pressures well in excess of the rated pressure without risk of bursting. Maintaining operating pressure at or below the pressure rating will ensure optimum life of the operating components.

psig	bar	kPA
100	6.9	690

Maintenance

Precautions



WARNING:

- All procedures must be performed by qualified personnel.
- When the process fluid is hazardous, thermal (hot or cold), or corrosive, take extra precautions. Employ the appropriate safety devices and be prepared to control a process media leak.
- O-ring failure on the upper cover of a fail open or double acting actuator can pressurize a switch package, if present. This may result in catastrophic failure of the switch package, causing the switch package cover to be released at high velocity. O-ring failure can be caused by:
 - Damage to the o-ring
 - O-ring material degrading
 - O-ring wear over time
- Always wear protective clothing and equipment to safeguard the eyes, face, hands, skin, and lungs from the particular fluid in the line.
- Do not disassemble the actuator in the field. The actuator contains energized springs which can cause injury. The product is designed to be recycled in its entirety.



CAUTION:

- Disconnect electrical, pneumatic, and hydraulic power before servicing actuator or automation components.

Inspection

The actuator cannot be disassembled and reassembled.

Inspection area	What to look for	Action if problem is found
External valve parts	Excessive wear or corrosion	<ul style="list-style-type: none"> • Replace the affected parts • Contact ITT to obtain replacement parts or for specific instructions
Non sealed bonnet	Fluid weeping from the plug	Replace the valve diaphragm
Actuator's bonnet weep hole and air ports	Air pressure	Contact ITT for specific instructions
Topworks	Spindle binding, excessive noise, or dried lubricant	<ul style="list-style-type: none"> • For manual topworks, lubricate the valve spindle • For actuated topworks, contact ITT for specific instructions
O-ring for COP manual topworks	Signs of wear or nicks	Replace the o-ring
Diaphragm and valve body	Leakage between the diaphragm and valve body	Tighten the bonnet fasteners

For more information, see:

- Replace the valve diaphragm in this manual.
- Tighten the bonnet fasteners in this manual.

Disassemble the valve

1. Remove all line pressure.
2. If the actuator mode of operation is fail open or fail close, then load the actuator with air.

If the actuator mode of operation is ...	Then ...
Fail open	Load the actuator with sufficient air to partially close the valve.
Fail close	Load the actuator with sufficient air to partially open the valve.

3. Remove the bonnet fasteners.
4. Lift the topworks assembly from the valve body.
5. If the actuator mode of operation is fail open, then remove pressure load from the actuator.

Replace the valve diaphragm

1. Disassemble the valve.
For more information, see Disassemble the valve in this manual.
2. Remove the diaphragm by rotating the diaphragm 90° so it slides out of the compressor.
The replacement diaphragm must be identical in grade to the original diaphragm.
3. If replacing a PTFE diaphragm, locate a new elastomer backing cushion over boss in diaphragm.
Align the bolt pattern of the backing cushion with that of the diaphragm.



4. If you have a fail open or double acting actuator, add air to the upper chamber to expose the compressor.
5. Invert diaphragm by pressing the center of the diaphragm face with your thumbs while holding the edge of the diaphragm with your fingers.

NOTICE:

Do not to scratch the diaphragm bead while inverting the diaphragm.



6. Insert the diaphragm into the compressor.
 - a) Insert the diaphragm stud with a cross pin into the compressor.
 - b) Rotate the diaphragm 90° to capture the pin in the compressor.

- c) Lightly tug on the diaphragm to ensure the pin has engaged in the compressor.
This also properly positions the bolt pattern of the diaphragm with that of the bonnet.



7. If replacing a PTFE diaphragm, re-invert the diaphragm.



8. If the actuator mode of operation is fail open or fail close, select one of these steps.

If the actuator mode of operation is ...	Then ...
Fail open	<ol style="list-style-type: none"> 1. Connect the air line to the upper actuator chamber. 2. Load the chamber with the full recommended air pressure. Be sure to apply enough air pressure to prevent inversion of the diaphragm. 3. Reduce the air pressure until the back of the diaphragm is flat against the bonnet.
Fail close	<ol style="list-style-type: none"> 1. Connect the air line to the bonnet's cylinder. 2. Load the chamber with sufficient air to move the diaphragm upward until the back of diaphragm is flat against the bonnet. Do not apply excessive air pressure that results in inversion of the diaphragm.
Double acting	Remove the air line.

9. Replace the topworks assembly on the body and tighten the bonnet fasteners.
For more information, see Tighten the bonnet fasteners in this manual.
10. If the actuator mode of operation is fail open, release the air, allowing the valve to open.
11. If there is a travel (closing) stop, reset it to ensure proper closure.
For more information, see Adjust the travel (closing) stop in this manual.

Travel (closing) stop for manual valve

A travel stop is included in all manual valve configurations. The purpose of the travel stop is to prevent over closing of the valve and prolong diaphragm life. IIT recommends you adjust the travel stop:

- during valve installation
- after diaphragm replacement
- after any other maintenance procedure

Use one of the following procedures to adjust the travel stop. IIT recommends you adjust the travel (closing) stop with air pressure whenever possible.

If ...	Then use this procedure ...
You have air pressure available	Adjust the travel (closing) stop with air pressure
You do not have air pressure available	Adjust the travel (closing) stop without air pressure

Adjust the travel (closing) stop with air pressure

1. With the valve slightly open, apply air pressure at 150 psig (10 bar) to the upstream side.

NOTICE:

Make sure that seal leakage is not excessive at this time as it will result in the whipping action of the flexible tube.

2. Connect the downstream side to a flexible tube immersed in a container of water.
Air bubbles should be evident in the water.
3. Remove the screw that secures the handwheel to the spindle.
4. Turn the handwheel clockwise until the air bubbles stop.
5. Push down on the handwheel and reinstall the screw.
The maximum allowable torque on this joint is 32 in-lbs (3.6 N-m).

Adjust the travel (closing) stop without air pressure

1. With system pressure vented, remove the screw securing the handwheel to the spindle and handwheel.
2. Using a wrench applied to the spindle flats, close the valve to the final torque as follows:

If diaphragm is ...	Then close to torque of ...
Elastomer	4 in-lbs (0.45 N-m)
PTFE	6 in-lbs (0.68 N-m)

3. Slide the handwheel over the spindle, push down, and reinstall the screw.
The maximum allowable torque on this joint is 32 in-lbs (3.6 N-m).

Lubrication requirements



WARNING:

Standard lubricants are as outlined below. Special lubricants may be required for oxygen or other unique services. Contact IIT for evaluation of non-standard lubricants.

NOTICE:

Re-lubrication is not intended for actuated valves. Actuator is not intended to be disassembled nor assembled in the field.

Lubrication schedule

Remove residual grease prior to re-lubrication. Lubricate the spindle, o-rings (for COP manual topworks), and mating surfaces whenever the topworks is disassembled.

Acceptable lubricants

Brand	Lubricant type
Chevron	FM ALC EP 2 (FDA Compliant)

Parts Listing and Cross-Sectional Drawings

Bio-Pure manual topworks

List of parts

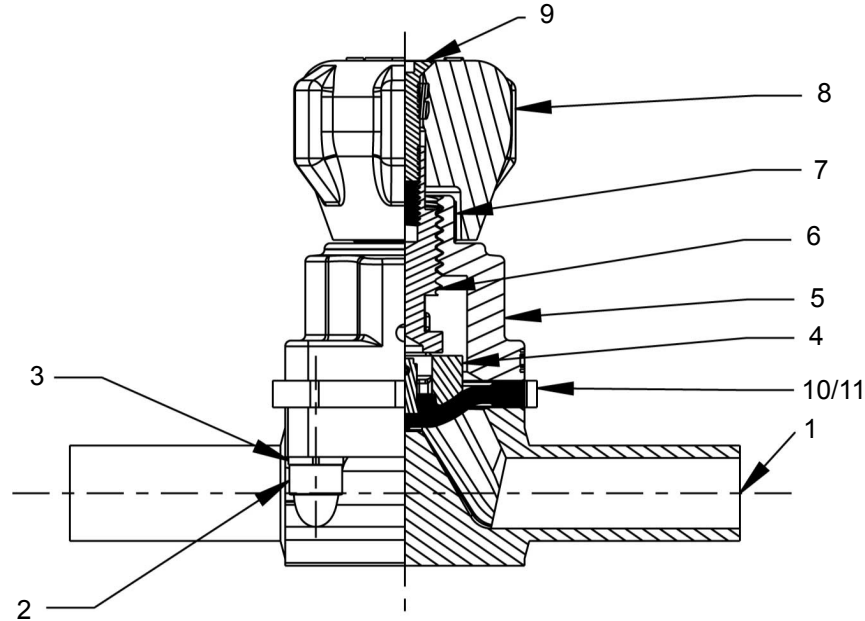

Figure 5

Item	Description	Material	Quantity
1	Body	Stainless steel	1
2	Screw	Stainless steel	4
3	Washer	Stainless steel	4
4	Compressor	Stainless steel	1
5	Bonnet	Stainless steel	1
6	Spindle	Stainless steel	1
7	Indicating label	Mylar	1
8	Handwheel	Plastic	1
9	Screw	Stainless steel	1
10 ¹	Diaphragm	As required	1
11 ¹	Backing cushion	As required	1

¹ Recommended spare part

Bio-Pure COP manual topworks

List of parts

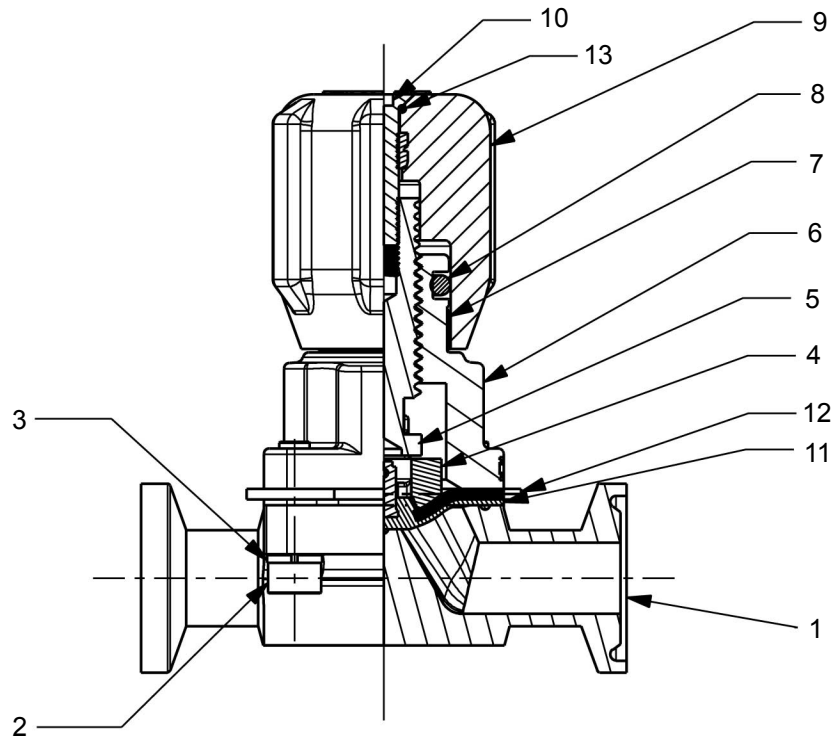

Figure 6

Item	Description	Material	Quantity
1	Body	Stainless steel	1
2	Screw	Stainless steel	4
3	Washer	Stainless steel	4
4	Compressor	Stainless steel	1
5	Spindle	Stainless steel	1
6	Bonnet	Stainless steel	1
7	Indicating label	Mylar	1
8	O-ring	FKM	1
9	Handwheel	Plastic	1
10	Screw, self sealing	Stainless steel, FKM	1
11 ²	Diaphragm	As required	1
12 ²	Backing cushion	As required	1
13	O-ring	FKM	1

² Recommended spare part

Bio-Pure AXS actuator

List of parts

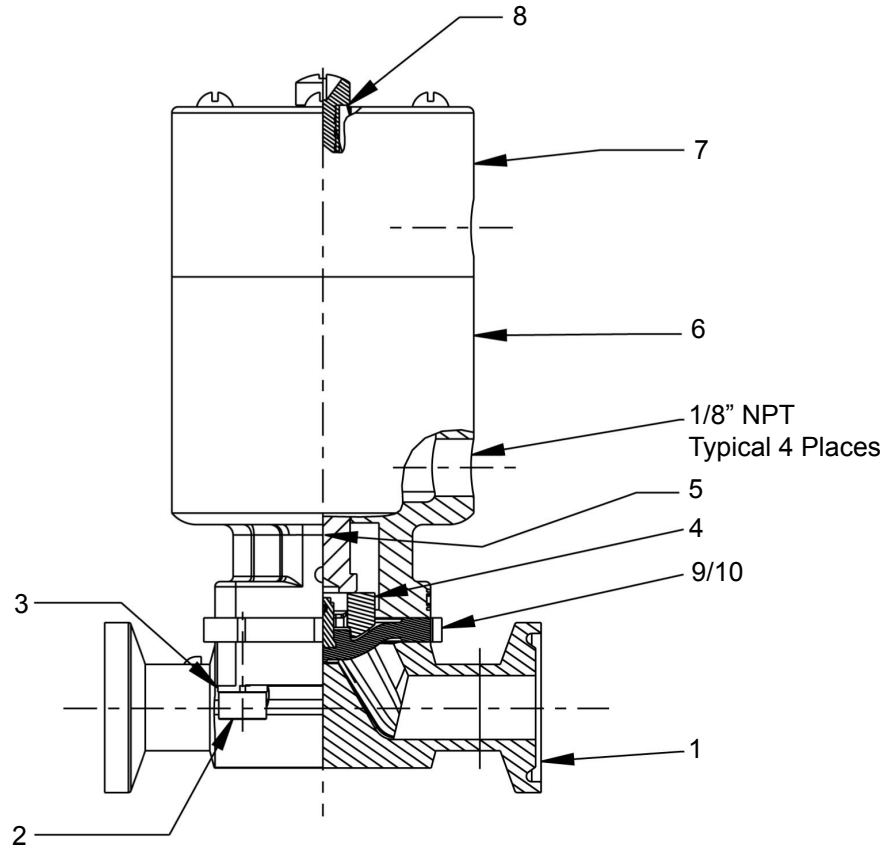

Figure 7

Item	Description	Material	Quantity
1	Body	Stainless steel	1
2	Screw	Stainless steel	4
3	Washer	Stainless steel	4
4	Compressor	Stainless steel	1
5	Spindle	Stainless steel	1
6	Bonnet	Stainless steel	1
7	Upper cover	Stainless steel	1
8	Indicating spindle	Stainless steel	1
9 ³	Diaphragm	As required	1
10 ³	Backing cushion	As required	1

³ Recommended spare part



ITT

Visit our Web site for the latest version of this document and more information
www.ittpureflo.com

ITT Pure-Flo
33 Centerville Road
Lancaster, PA 17603
USA
Tel. (717) 509-2200
Fax (717) 509-2316
E-mail: pureflo.custserv@itt.com

ITT Pure-Flo
Richards Street, Kirkham
Lancashire PR4 2HU
England
Tel. +44-1772-682696
Fax +44-1772-686006