

Block Body Zero Static “T” With Integral Sample Valve

Block Body Zero Static “T” with Integral Sample Valve

To assist in providing a more representative sample of water quality directly at a point-of-use application, Pure-Flo has developed a block bodied point-of-use valve fabrication utilizing an integral sample port. The Body is manufactured from ASTM A479 bar stock for high quality and ease of fabrication. The block body design permits welding of tube stubs directly to the exterior of the valve body eliminating the need of an interior elliptical weld necessary when inserting a tube directly through a forged body. In addition, the integral sample valve is integral to the main valve assembly which reduces contact surfaces and volume. The position of the sample valve to the main valve body also eliminates any question of its conformance to cGMP-6D requirements while greatly reducing the dead leg to less than 2D, which is unachievable in other sample valve orientations.

Material and Specifications

- 316L Stainless Steel, ASTM A479 wrought bodies, Pure-Flo main valve sizes 1.0" through 2.0" with 0.5" Bio-Tek® integral sample valve.
- Other size integral sample valves are available upon request, up to the size of the main valve.
- Standard ANSI 316L Stainless Tubing up to 4".
- Assembly available with FDA compliant PTFE and EPDM diaphragms.
- Interior surface finishes available with mechanical finishes from 11µ in. Ra 35µ in. Ra. Electropolish over mechanical services is also available.
- PAS, stainless steel, nylon coated, PVDF coated or white epoxy coated manual bonnet assemblies are available.
- Diaphragm driven pneumatic Advantage Actuators are available.

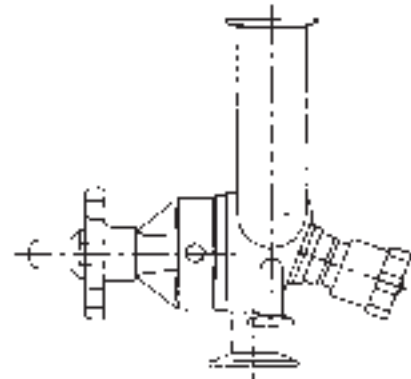
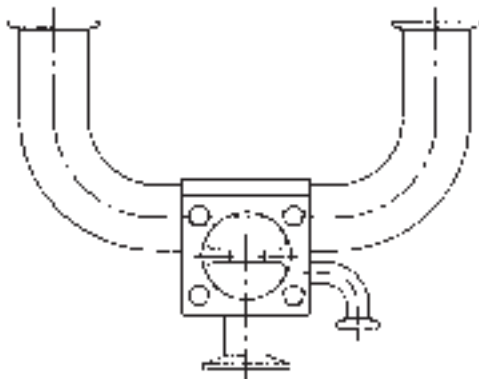
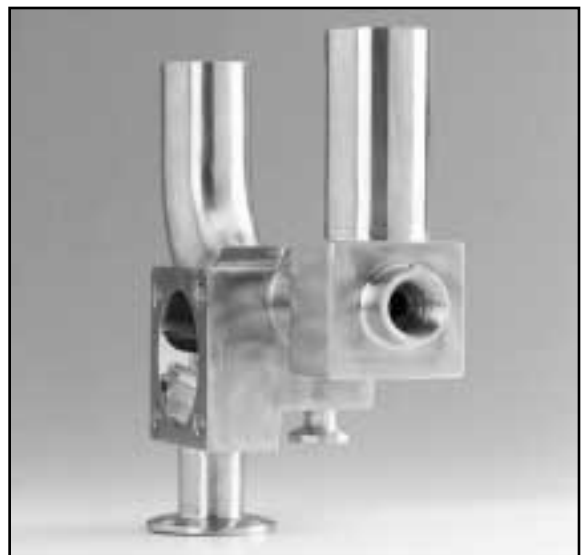

Pure-Flo Solutions Group

OFFICE LOCATIONS

For more information, please contact:

Engineered Valves Headquarters

33 Centerville Road, P.O. Box 6164

Lancaster, PA 17603-2064 USA

or call: (800) 366-1111
(717) 509-2200

Fax: (717) 509-2336

Website: www.engvalves.com

E-mail: engvalves_custserv@fluids.ittind.com

Pure-Flo Solutions Group

Headquarters

33 Centerville Road

Lancaster, PA 17603

Phone 800-366-1111
Phone (717) 508-2200
Fax (717) 509-2336

Pure-Flo California

Formerly ITT Sherotec

725 East Cochran Street, Unit E

Simi Valley, CA 93065

Phone 800-926-8884
Phone (805) 520-7200
Fax (805) 520-7205

Pure-Flo Sweden

Formerly A.G. Johansons Metallfabrik

Box 26 Vasterasvagen 6

S-730 40 Kolback

Sweden

Phone +46-220-403-20
Fax +46-220-405-23

Pure-Flo UK

Formerly Sinton Group

Richards Street

Kirkham, Lancashire

PR4 2HU, England

Phone +44-1772-682696
Fax +44-1772-686006