

DIA-FLO® & PURE-FLO® Diaphragm Valves Instruction Manual With Dia-Flo Actuator®

This manual provides installation and maintenance instructions for DIA-FLO ACTUATOR operated DIA-FLO/PURE-FLO diaphragm valves. If additional information is required, contact:

Engineered Valves
33 Centerville Road
Lancaster, PA 17603
(717) 509-2200
Attention: Sales Department

ITT INDUSTRIES VALVES AND VALVE ACTUATORS ARE DESIGNED AND MANUFACTURED USING GOOD WORKMANSHIP AND MATERIALS, AND THEY MEET ALL APPLICABLE INDUSTRY STANDARDS. THESE VALVES ARE AVAILABLE WITH COMPONENTS OF VARIOUS MATERIALS, AND THEY SHOULD BE USED ONLY IN SERVICES RECOMMENDED IN OUR PRODUCT CATALOG OR BY A COMPANY VALVE ENGINEER.

MISAPPLICATION OF THE PRODUCT MAY RESULT IN INJURIES OR PROPERTY DAMAGE. A SELECTION OF VALVE COMPONENTS OF THE PROPER MATERIAL CONSISTENT WITH THE PARTICULAR PERFORMANCE REQUIREMENTS, IS IMPORTANT FOR PROPER APPLICATION.

EXAMPLES OF THE MISAPPLICATION OR MISUSE OF ITT INDUSTRIES VALVES INCLUDE USE IN AN APPLICATION IN WHICH THE PRESSURE/TEMPERATURE RATING IS EXCEEDED OR FAILURE TO MAINTAIN VALVES AS RECOMMENDED.

IF VALVE EXHIBITS ANY INDICATION OF LEAKAGE, DO NOT OPERATE. ISOLATE VALVE AND EITHER REPAIR OR REPLACE.

CONTENTS

- 1.0 INSTALLATION
- 2.0 OPERATION & ADJUSTMENT
- 3.0 MAINTENANCE
- 4.0 ACCESSORIES
 - 4.1 PRESSURE CAP
 - 4.2 TRAVEL (CLOSING) STOP ADJUSTMENT
 - 4.3 HANDWHEEL OPENING DEVICE OPERATION
 - 4.4 WRENCH OPENING DEVICE OPERATION
 - 4.5 COMBINATION HANDWHEEL OR WRENCH OPENING DEVICE WITH ADJUSTABLE OPENING STOP
 - 4.6 HANDWHEEL CLOSING DEVICE AND ADJUSTABLE OPENING STOP
 - 4.7 MICROSWITCH LIMIT SWITCHES - ADJUSTMENT
 - 4.8 WESTLOCK MODULE 3 LIMIT SWITCHES
 - 4.9 POSITIONERS (TOP MOUNTED)

TABLES

- 1. BONNET FASTENER TORQUES
- 2. VALVE AND ACTUATOR TRAVEL
- 3. ACTUATOR INTERNAL DATA
- 4. VALVE OPERATING PRESSURES
- 5. O-RING SIZES

FIGURES

- 1. GLASS LINED BODY INSTALLATION
- 2. VALVE DIAPHRAGM IDENTIFICATION
- 3. ACTUATOR DIAPHRAGM IDENTIFICATION
- 4. ACTUATOR DRAWINGS
- 5. POSITION INDICATORS

- 6. TRAVEL STOPS
- 7. HANDWHEEL OPENING DEVICE
- 8. WRENCH OPENING DEVICE
- 9. COMBINATION HANDWHEEL OPENING OR WRENCH OPENING WITH ADJUSTABLE OPENING STOP
- 10. HANDWHEEL CLOSING DEVICE AND ADJUSTABLE OPENING STOP
- 11. LIMIT SWITCHES - PUSHBUTTON TYPE
- 12. LIMIT SWITCHES - WESTLOCK PROXIMITY TYPE
- 13. POSITIONERS (TOP MOUNTED)
- 14. PTFE DIAPHRAGM DETAIL

1.0 INSTALLATION

NOTE: WELD END VALVES

Weld end valves for schedule 10 and heavier pipe require bonnet and diaphragm removal prior to welding in line. See Section 3.5, 3.6, 3.7 or 3.8. Schedule 5 and lighter pipe and tubing may be welded with automatic equipment only without removing the diaphragm. Manual welding requires bonnet and diaphragm removal for all pipe schedules.

NOTE: GLASS LINED BODIES

Glass lined bodies have special installation instructions - See section 1.3.

NOTE: SOLID PLASTIC VALVES

Solid Plastic Valves are not recommended for installation in plastic lined piping systems. Also note threaded inserts are supplied in the base of the valve body and should be used for bracketing/supporting valves in accordance with cGMP's.

1. INSTALLATION

1.1 Dia-Flo diaphragm valves may be installed in any orientation. For horizontal piping systems to be drained through the valve, install the valve



stem between 0 and 30 degrees above horizontal. (After draining, a small pocket of fluid may remain in the valve.) **Note: Pure-Flo valves have either raised hash marks (castings) or small machined dots (forgings) on the valve body to indicate the correct drain angle. Locate these marks at the 12 o'clock position to achieve the optimum drain angle.**

- 1.2 Prior to pressurization (with the valve open), tighten the bonnet nuts in a crisscross pattern in accordance with Table 1. Retightening 24 hours after the system reaches operating temperature and pressure is recommended. If leakage occurs at the body/diaphragm seating area, immediately depressurize system and tighten bonnet nuts as noted above. If leakage continues, diaphragm replacement is required. Follow applicable steps in Section 3.5, 3.6, 3.7 or 3.8.
- 1.3 **INSTALLATION - GLASS LINED VALVE BODIES**
It is extremely important that all **glass lined** valves be installed with proper end flange gaskets and that proper torque be applied to the bolts in correct sequence. The use of PTFE plastic envelope gaskets with soft insert materials is recommended. See Figure 1 for proper bolt torque and sequence.
- 1.4 The **travel stop**, if equipped, is factory set and should not require adjustment at time of installation. However, if adjustment is required, see section 4.2.
- 1.5 Maximum valve operating pressures are shown in Table 4. Consult factory or Engineering Catalog for **vacuum** operation.
- 1.6 Air line connections should be made up with care as damage may occur to the standard aluminum actuator covers. Connection size is 1/4" NPT for #12 through #75 and 1/2" for #101 through #250.
2. **OPERATION & ADJUSTMENT**
 - 2.1 The Dia-Flo actuator is a spring-and-diaphragm, or double acting diaphragm, pneumatic actuator. The actuator **model number** is located on the ITT i.d. tag. The model number is a four or five digit number defining the actuator as follows:
 XXYYY
 if XX = 31 Direct Acting (Spring to Open)
 if XX = 32 Reverse Acting (Spring to Close)
 if XX = 33 Double Acting
 YYY = Nominal Size. Available sizes (approximate effective diaphragm area): #12, 25, 50, 75, 101, 130, 250. For two digit sizes, the final Y is left off.
 - 2.2 **Maximum permitted air supply pressure is 85 psig (586 kPa).**
 - 2.3 For operation and adjustment of actuator **accessories**, see Section 4.
 - 2.4 Valve and actuator **travel** are shown in Table 2. For any combination, the actual travel is the lesser of the two.
3. **MAINTENANCE**
 - 3.1 Periodically inspect condition of external valve parts. Replace all parts showing excessive wear or corrosion. Leakage from the bonnet weep hole indicates diaphragm rupture. For diaphragm replacement, see Section 3.5, 3.6,

3.7 or 3.8. On sealed bonnet valves, back off the v-notch vent plug two or three turns.

▲ WARNING:

When the process fluid is hazardous or corrosive, extra precautions should be taken. The user should employ appropriate safety devices and should be prepared to control a leak of the process fluid. Fluid weeping from the plug indicates a diaphragm failure. Replace diaphragm immediately. Failure to follow these instructions could result in serious personal injury or death and property damage.

- 3.2 Air pressure from the bonnet weep hole may indicate o-ring failure. Follow applicable replacement instructions given below.
- 3.3 If valve diaphragm flange area leaks, depressurize system and open valve slightly, using handwheel/wrench opening device (if equipped or local bleed type regulator. Tighten bonnet nuts as described in Section 1.2. If leakage continues, diaphragm replacement is required.
- 3.4 **Lubrication**
Standard lubricants are Sunoco 991EP for Dia-Flo valves and Chevron Poly FM2 (FDA Compliant) for Pure-Flo valves. Actuators equipped with a lube fitting should be lubricated every 6 months. Actuators without lube fittings should be lubricated in the spindle/adaptor bushing/o-ring area whenever the actuator is disassembled.
- 3.5 **Double Acting (See Figure 4(A))**
 - 3.5.1 **Valve Diaphragm Replacement**
 - 3.5.1.1 Disconnect air lines. Remove bonnet bolts and nuts. Lift actuator and bonnet assembly from valve body.
 - 3.5.1.2 Unscrew diaphragm from compressor by turning counterclockwise.
 - 3.5.1.3 For PTFE diaphragm assemblies only: replace backing cushion and PTFE diaphragm. Invert PTFE diaphragms prior to installation in tube nut. (To invert, hold edge of diaphragm with fingers while pressing in the center of the diaphragm face with thumbs.)
 - 3.5.1.4 Screw new diaphragm into compressor until hand tight, then back off until bolt holes in diaphragm and bonnet flange register.
 - 3.5.1.5 Replace actuator and bonnet assembly on body and tighten bonnet bolts with a wrench, crisscrossing from corner to corner. See Table 1 for torques.
 - 3.5.2 **Actuator Diaphragm Replacement**
 - 3.5.2.1 Disconnect air lines. Remove actuator bolts and nuts. Remove top cover.
 - 3.5.2.2 Remove spindle nut, diaphragm top plate and actuator diaphragm.
 - 3.5.2.3 Install new diaphragm. Reassembly is the reverse of the above. Apply Loctite 242 or equivalent on spindle threads when installing spindle nut.
 - 3.5.3 **Spindle O-Ring Replacement**
 - 3.5.3.1 Disconnect air lines, remove actuator and bonnet assembly as a unit from valve body and dismantle actuator following instructions above

- the removing actuator diaphragm.
- 3.5.3.2 Withdraw valve diaphragm, compressor and spindle assembly from the bonnet.
 - 3.5.3.3 Remove old o-ring, taking care not to damage machined surfaces. Lubricate new o-ring per Section 3.4 and install in groove. Reassemble reversing the above instructions:
- 3.6 Reverse Acting - 3212, 3225, 3250, 3275 -
See Figures 4(B), 4(C), 4(D)
- 3.6.1 Valve Diaphragm Replacement
- 3.6.1.1 Load the bottom chamber of the actuator with sufficient air to partially open valve. This will ease the spring tension holding the valve diaphragm to the body weir.
 - 3.6.1.2 Remove the bonnet bolts and nuts. Lift actuator and bonnet assembly from valve body. Release air and disconnect air line.
 - 3.6.1.3 Unscrew diaphragm from compressor by turning counterclockwise.
 - 3.6.1.4 For PTFE assemblies only: Replace backing cushion and PTFE diaphragm. **Note: It may be difficult to engage the threads of the diaphragm stud without inverting the diaphragm. To invert diaphragm, press on the center of the diaphragm face with thumbs while holding the edge of the diaphragm with fingers.**
 - 3.6.1.5 Screw new diaphragm into compressor by turning hand tight. Then back off until bolt holes in diaphragm and bonnet flange register.
 - 3.6.1.6 Connect air line to lower air chamber and load chamber with sufficient air to move the compressor approximately 1/8 of an inch.
 - 3.6.1.7 Replace actuator and bonnet assembly on body, and tighten bonnet bolts hand tight.
 - 3.6.1.8 Release air pressure and tighten bonnet bolts with a wrench, criss-crossing from corner to corner. See Table 1 for recommended torques.
 - 3.6.1.9 Apply air and open valve. If necessary, retighten bonnet bolts.
 - 3.6.1.10 Travel stop, if equipped, must be reset at this time to assure proper closure. See Section 4.2.
- 3.6.2 Actuator Diaphragm or Spring Replacement - **3212**
- 3.6.2.1 Remove four bolts and nuts at equal spacing around actuator cover and replace with four threaded rods approximately 6 inches long, secured by nuts on top and bottom of actuator flange.
 - 3.6.2.2 Remove the remaining bolts and nuts that clamp the actuator diaphragm. Turn the threaded rod nuts counterclockwise equally to gradually relax spring(s).
 - 3.6.2.3 Remove springs, spindle nut, upper plate and actuator diaphragm.
 - 3.6.2.4 Replace parts and reverse instructions for reassembly. Apply Loctite 242 on spindle nut.
- 3.6.3 Actuator Diaphragm or Spring Replacement - **3225**
- 3.6.3.1 Remove safety cap and jam nut from top of spring rod. Apply air to bottom chamber until valve is in open position.
 - 3.6.3.2 Tighten adjusting bushing until springs are compressed, then release air in bottom chamber. (If the actuator diaphragm is so badly ruptured that it is not possible to open the valve with air in the lower chamber, then it will be necessary to use the adjusting bushing as a jack-screw to compress the springs without the air assist.)
 - 3.6.3.3 Remove actuator nuts and bolts, releasing top cover containing spring assembly.
 - 3.6.3.4 Remove spindle nut, releasing top plate and actuator diaphragm.
 - 3.6.3.5 To remove springs, clamp upper cover flange in vice jaws and rotate adjusting bushing counterclockwise to relax springs.
 - 3.6.3.6 Replace parts and reverse instructions for reassembly. Apply Loctite 242 on spindle nut.
- 3.6.4 Actuator Spring Replacement - **3250 & 3275**
- 3.6.4.1 To replace spring, remove four nuts from columns, safety cap and jam nut from top of spring rod. Remove adjusting bushing, spring cover and springs.
 - 3.6.4.2 Replace parts and reverse instructions for reassembly.
- 3.6.5 Actuator Diaphragm Replacement - **3250 & 3275**
- 3.6.5.1 To replace actuator diaphragm, remove actuator bolts and nuts releasing actuator top cover. Remove spindle nut and top diaphragm plate.
 - 3.6.5.2 Replace parts and reverse instructions for reassembly. Apply Loctite 242 on spindle nut.
- 3.6.6 Spindle O-Ring Replacement - **3212, 3225, 3250 & 3275**
- 3.6.6.1 Disconnect air lines. Remove actuator and bonnet assembly from valve body and dismantle actuator following instructions above for removing actuator diaphragm and springs.
 - 3.6.6.2 Withdraw valve diaphragm, compressor and spindle assembly from the bonnet.
 - 3.6.6.3 Replace o-ring(s) and reassemble by reversing the instructions and following the steps for replacing a valve diaphragm. Lubricate o-ring(s) prior to installation per Section 3.4.
- 3.7 Reverse Acting - **32101, 32130, 32250** (see Figure 4(E))
- 3.7.1 Valve Diaphragm or Spring Replacement - see 3.6.1.
 - 3.7.2 Actuator Diaphragm Replacement
 - 3.7.2.1 Remove pressure from line

- containing valve and disconnect air line to lower cover.
- 3.7.2.2 Remove safety cap and hex jam nut from spring rod by rotating counterclockwise.
 - 3.7.2.3 Remove adjusting bushing by rotating counterclockwise. Place a ball thrust bearing over spring rod and replace adjusting bushing. An Aetna #E-33 (2-1/2" i.d. x 4" o.d. x 13/16" high) is recommended.
 - 3.7.2.4 Engage adjusting bushing on spring rod and rotate clockwise until it engages ball thrust bearing and is tightened down against top of spring casing.
 - 3.7.2.5 Continue to rotate adjusting bushing clockwise an additional 1/4" down spindle extension.
 - 3.7.2.6 Remove bonnet nuts by rotating counterclockwise and lift valve bonnet, including diaphragm and the actuator from valve body.
 - 3.7.2.7 Rotate adjusting bushing counterclockwise and remove from spring rod. Remove ball thrust bearing.
 - 3.7.2.8 Remove hex head cap screw and spring lock washers around base of spring casing by rotating counterclockwise.
 - 3.7.2.9 Lift off spring casing containing spring. This is a heavy unit. It is suggested that a chain fall be used, using the lifting eyelets located near the top of the spring casing.
- ⚠ WARNING**

Spring casing must be lifted up over spindle extension. Be careful not to bend spindle extension. Failure to follow these instructions could result in property damage and/or moderate personal injury. Spring(s) are captured in spring casing and are not removable. If spring replacement is necessary, replace entire casing assembly.
- 3.7.2.10 Remove hex nuts from hex head cap screws around periphery of actuator cover by rotating nuts counterclockwise.
 - 3.7.2.11 Lift off upper actuator cover.
 - 3.7.2.12 Rotate spindle connector counterclockwise to remove from actuator spindle. This has been assembled with Loctite sealant and may require extra torque or slight heat to release the sealant.
 - 3.7.2.13 Remove upper actuator plate.
 - 3.7.2.14 Remove actuator diaphragm and replace with new one.
 - 3.7.2.15 To reassemble, reverse the above procedure. Use air pressure instead of adjusting bushing to take load off of valve diaphragm. Apply Loctite 242 on spindle threads when installing spindle connector. Adjust travel stop per section 4.2.
- 3.7.3 Spindle O-Ring Replacement
 - 3.7.3.1 Remove pressure from line contain-

- ing valve and disconnect air line to lower cover.
- 3.7.3.2 Remove valve bonnet and actuator from valve body and disassemble in accordance with Section 3.7.2, steps 1 thru 13.
 - 3.7.3.3 Lift off actuator diaphragm and remove lower actuator plate.
 - 3.7.3.4 Slide diaphragm, compressor and valve spindle down out of the bonnet as a unit.
 - 3.7.3.5 Replace o-rings in adapter bushing. Lubricate o-rings per Section 3.4.
 - 3.7.3.6 To reassemble, reverse above procedures.
- 3.8 Direct Acting (See Figures 4(F), 4(G), 4(H), 4(I))
 - 3.8.1 Valve Diaphragm Replacement
 - 3.8.1.1 Disconnect air lines. Remove bonnet bolts and nuts. Lift actuator and bonnet assembly from valve body. Pressurize actuator, extending compressor and diaphragm.
 - 3.8.1.2 Unscrew diaphragm from compressor by turning counterclockwise.
 - 3.8.1.3 For PTFE assemblies only: Replace backing cushion and PTFE diaphragm. **Note: It may be difficult to engage the threads of the diaphragm stud without inverting the diaphragm. To invert diaphragm, press on the center of the diaphragm face with thumbs while holding the edge of the diaphragm with fingers.**
 - 3.8.1.4 Screw new diaphragm into compressor until hand tight. Then back off until bolt holes in diaphragm and bonnet register.
 - 3.8.1.5 Reduce air pressure until back of diaphragm is flat against bonnet. Replace actuator and bonnet assembly on body, and tighten bonnet bolts hand tight.
 - 3.8.1.6 Tighten bonnet bolts with a wrench, crisscrossing from corner to corner. See Table 1 for torques.
 - 3.8.1.7 Release air and open valve. If necessary, retighten bonnet bolts.
 - 3.8.2 Actuator Diaphragm or Spring Replacement - **3112 & 3125**
 - 3.8.2.1 Vent air pressure and disconnect air line.
 - 3.8.2.2 Remove actuator bolts and nuts.
 - 3.8.2.3 Remove spindle nut (3125: Remove hex-head screw, relaxing spring), diaphragm plates, actuator diaphragm and spring.
 - 3.8.2.4 Using replacement parts, reverse instructions for reassembly. Apply Loctite 242 on spindle nut.
 - 3.8.3 Actuator Diaphragm or Spring Replacement - **3150, 31101, 31130, 31250**

To replace springs:

 - 3.8.3.1 Vent air pressure and disconnect air line.
 - 3.8.3.2 3150: Remove four nuts and spring cover from columns.
31101-31250: Remove cap screws and nuts from around cap.
 - 3.8.3.3 Remove jam nut from spindle. Turn adjusting bushing counterclockwise, relaxing spring.

- 3.8.3.4 Remove spring seat and spring.
 - 3.8.3.5 Assemble in reverse order.
To replace actuator diaphragm, perform steps 1 through 5 above; then,
 - 3.8.3.6 Remove actuator bolts and nuts, releasing actuator upper cover.
 - 3.8.3.7 Unscrew spindle coupling to remove diaphragm plates and actuator diaphragm.
 - 3.8.3.8 Replace parts, including gaskets, and reverse instructions for reassembly. Apply Loctite 242, to spindle threads (#12, 50-250) or hex head bolt (#25), when installing spindle nut or spindle coupling.
- 3.8.4 O-Ring Replacement
- 3.8.4.1 Disconnect air lines. Remove actuator and bonnet assembly from valve body and dismantle actuator following above instructions for removing actuator diaphragm.
 - 3.8.4.2 Withdraw valve diaphragm, compressor and spindle assembly from the bonnet.
 - 3.8.4.3 Replace o-ring and reassemble by reversing the instructions and following the steps for replacing a valve diaphragm. Lubricate o-rings prior to installation per Section 3.4.

4. ACCESSORIES

4.1 Pressure Cap (Figure 6)

Pressure Caps are used with adjustable travel stops and other accessories. To remove pressure cap, ensure that upper chamber of actuator is unpressurized. Rotate pressure cap counterclockwise to remove.

Pressure Cap O-Rings:

Actuator Size	O-Ring
#12	219 (213 with ductile iron cover)
#25	220
All Others	333

4.2 Travel (Closing) Stop Adjustment (Note: Travel Stops are standard on 3225-32250 and available on all actuators.)

The purpose of the travel stop is to prevent overloading of the diaphragm, thus prolonging diaphragm life. Travel stops are factory set and do not require routine adjustment. However, with replacement of valve diaphragms, travel stop adjustment is recommended. Refer to Figure 6 for all direct and double acting, and all #12 actuators. Refer to Figure 4 C, D & E for 3225-32250 actuators.

4.2.1 Reverse Acting

If actuator has handwheel (code HWO) (Figure 7) or wrench opening device (code WO) (Figure 8), this device also serves travel stop function.

If 3212 actuator has adjustable opening stop (code TOWO), the opening stop must be removed. To remove opening stop rotate pressure cap counterclockwise and lift off. For other sizes with combination hand-wheel/wrench opening device and adjustable opening stop, see Section 4.5.

4.2.1.1 Release any air pressure in bottom chamber.

4.2.1.2 3212: Remove pressure cap by rotating counterclockwise.

4.2.1.3 3225-32250: Remove safety shield by loosening the two mounting screws.

4.2.1.4 To adjust travel (closing) stop, loosen jam nut. Turn adjusting bushing or stop nut clockwise (or turn handwheel counterclockwise) until valve leaks. Then turn counterclockwise (or turn handwheel clockwise) until the valve just stops leaking. Tighten jam nut. Travel stop is now set.

4.2.2 Direct and Double Acting

The travel stop (code ATS) is housed within a pressure cap, which is pressurized along with the upper chamber. **Note: If furnished with an adjustable opening stop (code TOHC) or handwheel closing device (code TOHC), these mechanisms will protrude through the top of the pressure cap.** To adjust the travel stop, however, the pressure cap must be removed.

4.2.2.1 Vent air from the upper chamber. Remove pressure cap by rotating counterclockwise. Loosen jam nut.

4.2.2.2 Adjust travel stop nut until the gap below the nut is equal to the valve or actuator travel, whichever is less (Table 2). Tighten jam nut.

4.2.2.3 Install pressure cap, making sure o-ring is properly installed.

4.2.2.4 Pressurize actuator. If valve leaks: Repeat step 1. Back off stopnut slightly by turning counterclockwise. Install pressure cap and pressurize actuator. Repeat this process as necessary until valve does not leak.

4.3 Handwheel Opening Device Operation (Figure 7)

The purpose of the optional handwheel opening device is to open a reverse acting (3200 series) actuator in the event of a diaphragm or plant air failure.

Loosen jam nut. Rotate handwheel counterclockwise to open. Rotate clockwise to return the valve to the closed position. Note: Handwheel must be returned precisely to its original position to maintain proper travel stop adjustment. See Section 4.2 to adjust travel stop.

4.4 Wrench Opening Device Operation

The purpose of the optional wrench opening device is to open a reverse acting (3200 series) actuator in the event of an actuator diaphragm or plant air failure.

4.4.1 3212 Wrench Opening Device (Figure 9(b))

4.4.1.1 Remove pressure cap. Loosen jam nut.

4.4.1.2 Rotate stop nut clockwise to open valve. Rotate stop nut counterclockwise to return valve to the closed position. **Note: Travel stop adjustment is recommended at this time. See Section 4.2.**

4.4.1.3 Tighten jam nut and install pressure cap.

4.4.2 3225-32130 Wrench Opening Device (Figure 8)

4.4.2.1 Remove safety cap. Loosen jam nut.

4.4.2.2 Rotate adjusting bushing clockwise to open valve. Rotate adjusting

bushing counterclockwise to return valve to the closed position. **Note: Travel stop adjustment is recommended at this time. See Section 4.2 to adjust travel stop.**

- 4.4.2.3 Tighten jam nut and install safety cap.
- 4.5 Combination Handwheel or Wrench Opening Device with Adjustable Opening Stop (Figure 9(A))
 - 4.5.1 3225-32130 Operation of Wrench Opening Device
 - 4.5.1.1 Loosen jam nut (1).
 - 4.5.1.2 Rotate wrench opening nut clockwise to open valve. Rotate counterclockwise to return valve to the closed position. Tighten jam nut. **Note: Travel stop adjustment is recommended at this time. See Section 4.2 to adjust travel stop.**
 - 4.5.2 3225-32130 Operation of Handwheel Opening Device (Figure 9(A))
 - 4.5.2.1 Loosen jam nut (1) above handwheel.
 - 4.5.2.2 Rotate handwheel counterclockwise to open valve. Rotate clockwise to return valve to the closed position. Tighten jam nut (1). **Note: Travel stop adjustment is recommended at this time. See Section 4.2 to adjust travel stop.**
 - 4.5.3 3225-32130 Operation of Adjustable Opening Stop
 - 4.5.3.1 Loosen jam nut (2) above spring cover.
 - 4.5.3.2 Using air pressure and bleed type regulator, open valve to desired position.
 - 4.5.3.3 Rotate adjusting bushing clockwise until resistance is felt.
 - 4.5.3.4 Tighten jam nut (2). Opening stop is now set.
- 4.6 Handwheel Closing Device and Adjustable Opening Stop (Figure 10) (3100 & 3300 series)

These options are very similar. Both use an adjusting screw to either limit valve opening travel or manually stroke the valve to the closed position. The handwheel closing device simply uses a handwheel rather than a hex head to rotate the screw.

 - 4.6.1 Operation of Adjustable Opening Stop:
 - 4.6.1.1 Use bleed type regulator and air supply to move valve to the desired position. Loosen jam nut.
 - 4.6.1.2 Rotate adjusting screw or handwheel clockwise until contact with the valve spindle is felt. Tighten jam nut. Opening stop is now set.

⚠ WARNING
If upper chamber is pressurized during this adjustment, leakage will occur past the adjusting spindle. Note that the adjusting screw cannot be completely removed. Means are provided on the inboard side of the adjusting screw to prevent removal. Failure to follow these instructions could result in property damage and/or moderate personal injury.

- 4.6.2 Operation of Handwheel Closing Device (or adjustable opening stop when used as manual override):
 - 4.6.2.1 Vent air from actuator. Loosen jam nut.
 - 4.6.2.2 Rotate handwheel (or hex head bolt) clockwise to close valve. Tighten jam nut.
- 4.7 MicroSwitch Limit Switches (Model Nos. BZE6-2RN, BAF1-2RN, DTE6-2RN, DTF2-2RN, EXQ, EXDQ) - Adjustment (See Figure 11)

This section provides instructions for adjustment of the above switches when mounted to the actuator covers (not yoke mounted). These switches are pushbutton type, actuated by a lever attached to the actuating rod. On #12 actuators, the actuating rod is attached directly to the actuator diaphragm plate. On sizes 25-250, the actuating rods are spring loaded. Contact with the diaphragm plate occurs only during the last 1/4" of travel.

 - 4.7.1 Adjustment (#12 Actuator)
 - 4.7.1.1 Loosen lever adjustment screws. Open valve.
 - 4.7.1.2 Move open switch operating lever until open switch makes an audible click. Tighten open switch lever adjustment screws.
 - 4.7.1.3 Open switch is now set. Verify set point by checking continuity on switch terminals.
 - 4.7.1.4 Close valve and repeat the above procedure for the valve closed switch.
 - 4.7.2 Adjustment (#25-250 Actuator)
 - 4.7.2.1 Open valve slowly. Note: if actuating lever has previously been mis-adjusted, lever may overtravel switch and become damaged.
 - 4.7.2.2 Loosen lever attachment screws. **Note: Actuating rod is spring loaded. If rod is not bearing against diaphragm plate, spring may force actuating rod entirely within actuator. Actuator must be disassembled to retrieve.**
 - 4.7.2.3 Move actuating lever until switch makes an audible click. Verify set-point by checking continuity on switch terminals. Open switch is now set.
 - 4.7.2.4 Repeat the above procedure for the valve closed switch. Same cautions apply.
- 4.8 Westlock Module3 Proximity Switches - See Figure 12
 - 4.8.1 Description

These proximity switches are actuated by magnetic triggers. The triggers, along with sensing end of the switches, are inside a protective metal enclosure. The switch leads and all electrical terminations are inside a separate, sealed, explosion proof enclosure. Refer to the manufacturer's literature for the precise enclosure ratings.

In addition, a solenoid valve may be attached directly to the switch enclosure via the solenoid's conduit connection. The solenoid leads may then be terminated at the switch terminal strip.

4.8.2 Adjustment

- 4.8.2.1 Open valve. Remove the four screws holding the bracket cover to the bracket. Remove bracket cover.
- 4.8.2.2 Loosen jam nuts on valve open switch trigger and slide to bottom of slot. Tighten jam nuts. A horizontal distance of 1/16" to 1/8" should be maintained between the trigger and the switch.
- 4.8.2.3 Attach continuity tester to valve open switch contacts.
- 4.8.2.4 Loosen setscrew. Slide trigger bracket assembly up until switch contacts change state. Tighten setscrew.
- 4.8.2.5 Close valve. Loosen jam nuts on valve closed switch trigger.
- 4.8.2.6 Attach continuity tester to valve closed switch contacts. Slide valve closed switch trigger down until switch contacts change state.
- 4.8.2.7 Tighten jam nuts. Switches are now set.
- 4.8.2.8 Install bracket cover and four screws.

4.9 Positioners (See Figure 13)

- 4.9.1 Scope: Top-mounted positioners listed below
 - 4.9.1.1 Moore 73N12F (3100 & 3300 Series Actuators)
 - 4.9.1.2 Moore 73NB (3200 Series Actuators)
 - 4.9.1.3 ITT Conoflow GC31 (3100 & 3300 Series Actuators)
 - 4.9.1.4 ITT Conoflow GC33 (3200 Series Actuators)
- 4.9.2 Supply and Instrument Pressures
 - 4.9.2.1 Instrument input pressure range - as specified: 3-15 psi (standard), 3-9 psi, 6-30 psi and others are optional.
 - 4.9.2.2 Supply pressure: 3 psi above required actuator pressure to a maximum of 85 psi. A filtered air supply is recommended.

<p style="text-align: center;">⚠ WARNING</p> <p>Pressure in excess of 85 psi to any connection may cause damage. Failure to follow these instructions could result in property damage and/or moderate personal injury.</p>

4.9.3 Description

The positioner is designed to operate a valve actuator to maintain the valve in a position determined by the control instrument. The above positioners are direct acting - with an increase in instrument pressure, the valve actuator pressure (positioner output) will increase. On a bottom loading positioner (73 NB and GC33), output is connected to the actuator lower chamber via an external tube. Therefore, the valve will open as instrument pressure increases. On a **top-loading positioner**, the output is

applied directly to the actuator directly through the actuator housing (no external tubing). The valve will close as instrument pressure is increased.

4.9.4 Installation

The only task is to connect the supply and instrument air. All connections are 1/4" NPT. See Figure 13. Use 1/4" O.D. tubing for the instrument connection, either 1/4" or 3/8" O.D. tubing for the supply connection. Blow out all piping before connections are made to prevent the possibility of dirt or chips entering the positioner. Use pipe sealant sparingly, and then only on the male threads. A non-hardening sealant is strongly recommended. Connect the positioner to a source of clean, dry oil-free air. A filtered and regulated air source is recommended. **Note: Synthetic compressor lubricants in the air stream at the instrument may cause the positioner to fail.**

Note that a cushion loading regulator is furnished with 3300 series actuators and a tee in the supply connection is routed to this regulator, so an extra hookup is not required. The cushion loading regular should be set at the minimum pressure required to open the valve wide open. Typically, this is 10 psi or less.

4.9.5 Adjustment

The only adjustment that can be made on the positioner is a zero adjustment. The zero adjusting screw is located under the positioner's top cover. To adjust the zero, set the instrument air pressure to the mid-point of its span, and turn the zero adjustment until the valve is at the mid-point of its stroke. (To determine valve stroke, refer to Table 2.) Recheck the setting accuracy by changing instrument air pressure to the maximum/minimum point to obtain full open/closed valve position.

In some cases, valve shut-off opening may be required at a specific instrument pressure. To zero the positioner at this point, set the instrument signal at the specific pressure and turn the zero adjustment screw until the valve reaches the required position. A slight change of the instrument pressure should start to move the valve. The valve stroke for a given span may also be suppressed or shifted to the desired range by means of the zero adjusting screw.

4.9.6 Maintenance

A clean, oil and moisture free air supply will reduce maintenance problems. The supply air filter should be blown down on a routine basis. The filter element should be examined periodically and replaced if necessary. No lubrication is required on the valve positioner. The system should be shut down or the valve isolated from the system before service or removal of the positioner is accomplished.

For additional maintenance activities, refer to the manufacturer's service manual.

TABLE 1
BONNET FASTENER TORQUES IN INCH-POUNDS

Bonnet		Metal			Plastic	
Body		All Weir & Straightway (Except Glass Lined)		Glass Lined Weir & Straightway		All
Diaphragm		Elastomer	PTFE	Elastomer	PTFE	All
Size						
IN	DN					
1/2	15	40	80	40	40	18
3/4*	20	48	80	48	80	18
1	25	48	100	48	80	25
1 1/4	32	48	100	48	80	—
1 1/2	40	48	220	48	110	75
2	50	96	275	96	170	100
2 1/2	60	192	575	192	200	—
3	80	300	1000	300	300	420
4	100	192	575	192	360	180
6	150	480	1200	480	600	—
8	200	480	1200	480	600	—
10	250	480	1200	480	—	—
12	300	480	1200	480	—	—

NOTES:

- 1) Torque may be exceeded by up to 10%.
- 2) Bolt tension developed using torque wrenches can vary widely depending on fastener condition, wrench accuracy, degree of lubrication and technique. If fastener yielding or galling is apparent, reduce torque accordingly and replace fasteners.
- 3) Stainless steel studs/bolts with stainless steel nuts have Carbowax® 3350 applied at the factory. Stainless steel studs/bolts with bronze nuts have no lubricant. Subsequent field lubricant is not necessary.

*For 3/4" w/flanged ends, use 1" data except solid plastic.

TABLE 2
VALVE AND ACTUATOR TRAVEL

Actual travel for any valve and actuator combination is the lesser of the valve or actuator travel listed below.

WEIR							
Actuator Size	12	25	50	75	101	130	250
Stroke	5/8"	2"	3"	3"	3 1/8"	3 1/2"	4 5/8"

WEIR													
Valve Size	1/2	3/4*	1	1 1/4	1 1/2	2	2 1/2	3	4	6	8	10	12
**Stroke	1/4	3/8	1/2	5/8	13/16	1 1/8	1 3/8	1 5/8	2 1/8	3 1/8	4 5/8	5 5/8	6 1/2

*Stroke for 3/4" flanged weir valve is 1/2" except solid plastic.

STRAIGHTWAY							
Actuator Size	12	25	50	75	101	130	250
Stroke	5/8"	2"	3"	3"	3 1/8"	3 1/2"	4 5/8"

STRAIGHTWAY												
Valve Size	1/2	1	1 1/2	2	2 1/2	3	4	6	8	10	12	
**Stroke	15/32	15/16	1 1/4	1 7/8	2	2 5/16	2 13/16	4 1/4	6 1/4	7 1/2	7 1/2	

AIR MOTOR FLANGE BOLTING & SPINDLE NUT TORQUES

Air Motor Size	Flange Bolt Torque (in-lb)	Spindle Nut Torque (in-lb)
12	30	48
25	72	144
50	72	144
75	72	312
101	72	540
130	72	540
250	210	540

*Spindle nuts should be assembled with #271 (red) Loctite.

TABLE 3

Actuator internal dimensions

Size	Stroke	Air Connection	Effective Diaphragm Area (Sq. in.)	Actuator Volume (cu. in.)					
				Bottom Chamber		Upper Chamber			
				Double & Reverse Acting		Double Acting		Direct Acting	
				Open	Closed*	Open	Closed*	Open	Closed*
12	5/8"	1/4"	11.5	13.25	6.8	6.1	12.5	6.1	12.5
25	2"	1/4"	22.5	90.3	21.7	13.4	85.1	13.4	85.1
50	3"	1/4"	50	321.0	63.4	71.1	329.0	364	622
75	3"	1/4"	75	374.7	128.1	80.9	422.0	—	—
101	3 1/8"	1/2"	100	528.0	174.0	144.0	498.0	579	933
130	3 1/2"	1/2"	130	698.7	202.9	212.0	710.9	647	1146
250	4 5/8"	1/2"	250	1650.0	750.0	675.0	1760.0	1110	2195

*Using stroke of largest valve for which actuator is suitable

TABLE 4
VALVE OPERATING PRESSURES

The operating pressures listed below have been set to provide long operating life. Pressure tests indicate that ITT/Dia-Flo® diaphragm valves withstand pressures far in excess of their rated values. The pressures listed below are applicable up to 120°F. Valves at maximum pressures cannot be used at maximum temperatures. IMPORTANT: The actuator size being used may limit actual operating pressures. Consult the Engineering Catalog for actuator sizing.

WEIR

Valve size (inches)	Maximum pressure, psi	
	Handwheel operated	
1 1/4, 3 1/8	200	
1 1/2, 3 1/4, 1	200	
1 3/4, 1 1/2, 2	175	
2 1/2	150	
3	150	
4	150	
6	125	
8	100	
10, 12	65	

For solid plastic valves, see catalog.

STRAIGHTWAY

Valve Size	Maximum pressure, psi
1/2, 1, 1 1/2, 2, 2 1/2, 3	100
4	85
6, 8	50
10, 12	40

TABLE 5(A)
WEIR VALVE O-RINGS
(For O-Ring A or B, see Figure 4)

DOUBLE ACTING ACTUATORS														
ACTUATOR SIZE	VALVE SIZES													
		1/2	3/4	1	1-1/4	1-1/2	2	2-1/2	3	4	6	8	10	12
3312	A	112	112	112	114	114	114	—	—	—	—	—	—	—
	B	—	—	—	—	—	—	—	—	—	—	—	—	—
3325	A*	114	114	114	114	116	116	214	214	214	—	—	—	—
	B	326	326	326	326	326	326	326	326	326	—	—	—	—
3350	A*	—	—	—	—	116	116	214	214	214	214	—	—	—
	B	—	—	—	—	326	326	326	326	326	326	—	—	—
3375	A*	—	—	—	—	116	116	214	214	214	214	—	—	—
	B	—	—	—	—	326	326	326	326	326	326	—	—	—
33101	A	—	—	—	—	214 TWO REQUIRED								
	B	—	—	—	—	238								
33130	A	—	—	—	—	214 TWO REQUIRED								
	B	—	—	—	—	238								
33250	A	—	—	—	—	214 TWO REQUIRED								
	B	—	—	—	—	238								

* Two required if sealed bonnet is used.

DIRECT ACTING ACTUATORS														
ACTUATOR SIZE	VALVE SIZES													
		1/2	3/4	1	1-1/4	1-1/2	2	2-1/2	3	4	6	8	10	12
3112	A**	112	112	112	114	114	114	—	—	—	—	—	—	—
	B	—	—	—	—	—	—	—	—	—	—	—	—	—
3125	A*	114	114	114	114	116	116	214	214	214	—	—	—	—
	B	—	—	—	—	—	—	—	—	—	—	—	—	—
3150	A*	—	—	—	—	116	116	214	214	214	214	—	—	—
	B	—	—	—	—	326	326	326	326	326	326	—	—	—
31101	A	—	—	—	—	214 TWO REQUIRED								
	B	—	—	—	—	238								
31130	A	—	—	—	—	214 TWO REQUIRED								
	B	—	—	—	—	238								
31250	A	—	—	—	—	214 TWO REQUIRED								
	B	—	—	—	—	238								

** Used with sealed bonnet only.

* Two required if sealed bonnet is used.

REVERSE ACTING ACTUATORS														
ACTUATOR SIZE	VALVE SIZES													
		1/2	3/4	1	1-1/4	1-1/2	2	2-1/2	3	4	6	8	10	12
3212	A	112	112	112	114	114	114	—	—	—	—	—	—	—
	B	—	—	—	—	—	—	—	—	—	—	—	—	—
3225	A*	114	114	114	114	116	116	214	214	214	—	—	—	—
	B	326	326	326	326	326	326	326	326	326	—	—	—	—
3250	A*	—	—	—	—	116	116	214	214	214	214	—	—	—
	B	—	—	—	—	326	326	326	326	326	326	—	—	—
3275	A*	—	—	—	—	116	116	214	214	214	214	—	—	—
	B	—	—	—	—	326	326	326	326	326	326	—	—	—
32101	A	—	—	—	—	214 TWO REQUIRED								
	B	—	—	—	—	238								
32130	A	—	—	—	—	214 TWO REQUIRED								
	B	—	—	—	—	238								
32250	A	—	—	—	—	214 TWO REQUIRED								
	B	—	—	—	—	238								

* Two required if sealed bonnet is used.

TABLE 5(B)
STRAIGHTWAY VALVE O-RINGS
(For O-Ring A or B, see Figure 4)

DOUBLE ACTING ACTUATORS												
ACTUATOR SIZE	VALVE SIZES											
		1/2	1	1-1/2	2	2-1/2	3	4	6	8	10	12
3312	A	112	—	—	—	—	—	—	—	—	—	—
	B	—	—	—	—	—	—	—	—	—	—	—
3325	A*	114	114	116	116	214	—	—	—	—	—	—
	B	326	326	326	326	326	—	—	—	—	—	—
3350	A*	—	114	116	116	214	214	214	214	—	—	—
	B	—	326	326	326	326	326	326	326	—	—	—
3375	A*	—	114	116	116	214	214	214	214	—	—	—
	B	—	326	326	326	326	326	326	326	—	—	—
33101	A	—	—	—	214	TWO REQUIRED				—	—	—
	B	—	—	—	238					—	—	—
33130	A	—	—	—	—	214	TWO REQUIRED				—	—
	B	—	—	—	—	238					—	—
33250	A	—	—	—	—	214	TWO REQUIRED					—
	B	—	—	—	—	238						—

* Two required if sealed bonnet is used.

DIRECT ACTING ACTUATORS												
ACTUATOR SIZE	VALVE SIZES											
		1/2	1	1-1/2	2	2-1/2	3	4	6	8	10	12
3112	A**	112	—	—	—	—	—	—	—	—	—	—
	B	—	—	—	—	—	—	—	—	—	—	—
3125	A*	114	114	116	116	214	214	214	214	—	—	—
	B	—	—	—	—	326	326	326	326	—	—	—
3150	A*	—	114	116	116	214	214	214	214	—	—	—
	B	—	326	326	326	326	326	326	326	—	—	—
31101	A	—	—	—	—	214	TWO REQUIRED				—	—
	B	—	—	—	—	238					—	—
31130	A	—	—	—	—	214	TWO REQUIRED				—	—
	B	—	—	—	—	238					—	—
31250	A	—	—	—	—	214	TWO REQUIRED					—
	B	—	—	—	—	238						—

** Used with sealed bonnet only.

* Two required if sealed bonnet is used.

DIRECT ACTING ACTUATORS												
ACTUATOR SIZE	VALVE SIZES											
		1/2	1	1-1/2	2	2-1/2	3	4	6	8	10	12
3225	A*	114	114	—	—	—	—	—	—	—	—	—
	B	326	326	—	—	—	—	—	—	—	—	—
3250	A*	—	114	116	116	214	214	—	—	—	—	—
	B	—	326	326	326	326	326	—	—	—	—	—
3275	A*	—	114	116	116	214	214	214	—	—	—	—
	B	—	326	326	326	326	326	326	—	—	—	—
32101	A	—	—	—	—	214	TWO REQUIRED				—	—
	B	—	—	—	—	238					—	—
32130	A	—	—	—	—	214	TWO REQUIRED				—	—
	B	—	—	—	—	238					—	—
32250	A	—	—	—	—	214	TWO REQUIRED					—
	B	—	—	—	—	238						—

* Two required if sealed bonnet is used.

FIGURE 1
INSTALLATION — GLASS LINED BODIES

Important

It is extremely important that all glass lined valves be installed with proper end flange gaskets and that proper torque be applied to the bolts in correct sequence. The use of PTFE plastic envelope gaskets with soft insert materials is recommended. See proper bolt torque and sequence at right.

PROPER BOLTING
SEQUENCE

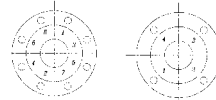

(VALVE END FLANGE)

RECOMMENDED
TORQUE

Valves	(lb.-Ft.)
00.50"-01.50"	20-30
02.00"-02.50"	30-60
03.00"-04.00"	40-70
06.00"	55-110
08.00"	60-110

FIGURE 2

VALVE DIAPHRAGM IDENTIFICATION

ELASTOMER — 1 PIECE, MADE OF RUBBER, WITH MOLDED-IN STUD.
(SEE TABS)

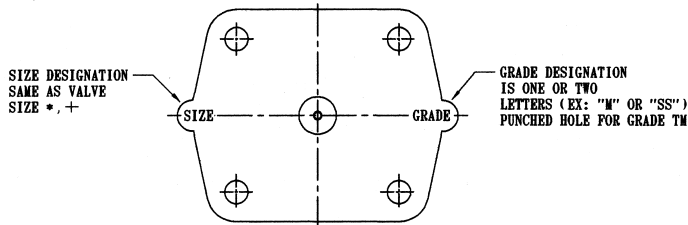

SIZE DESIGNATION
SAME AS VALVE
SIZE *, +

GRADE DESIGNATION
IS ONE OR TWO
LETTERS (EX: "M" OR "SS")
PUNCHED HOLE FOR GRADE TM

R2, TM (PTFE)
THESE DIAPHRAGMS ARE TWO-PIECE, WHITE PLASTIC WITH A
BLACK ELASTOMER BACKING.

* For 00.75 with flanged ends use 01.00 diaphragm except for solid plastic.
+ For 01.25 solid plastic uses 01.50 diaphragm.

FIGURE 3

ACTUATOR DIAPHRAGM IDENTIFICATION

Diaphragms

Size	Actuator Diaphragms						
	#12	#25	#50	#75	#101	#130	#250
A	6 ⁵ / ₁₆ "	9 ⁷ / ₁₆ "	13 ⁵ / ₁₆ "	14"	15 ¹¹ / ₁₆ "	14 ⁹ / ₁₆ "	21 ⁷ / ₁₆ "
Bolt Holes	12	18	← NONE →				
maximum recommended air pressure: 85 psi							

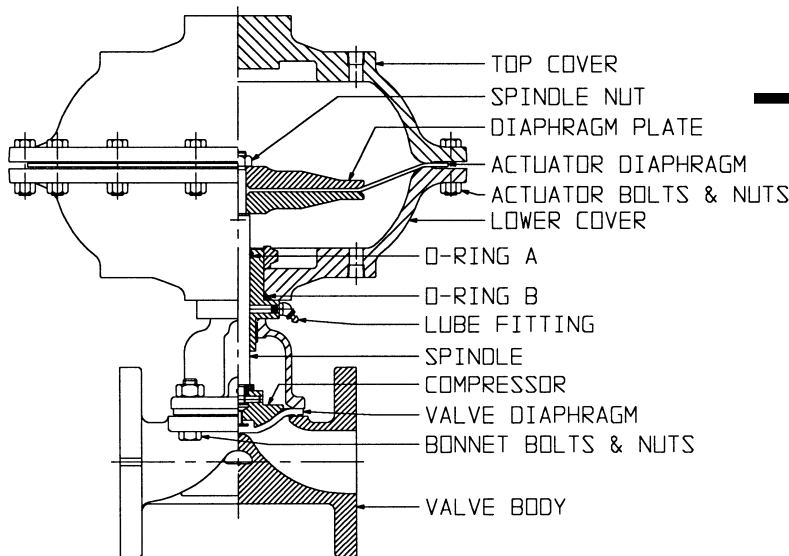
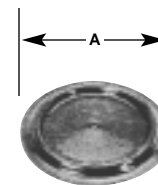

FIGURE 4(A)
3312-33250

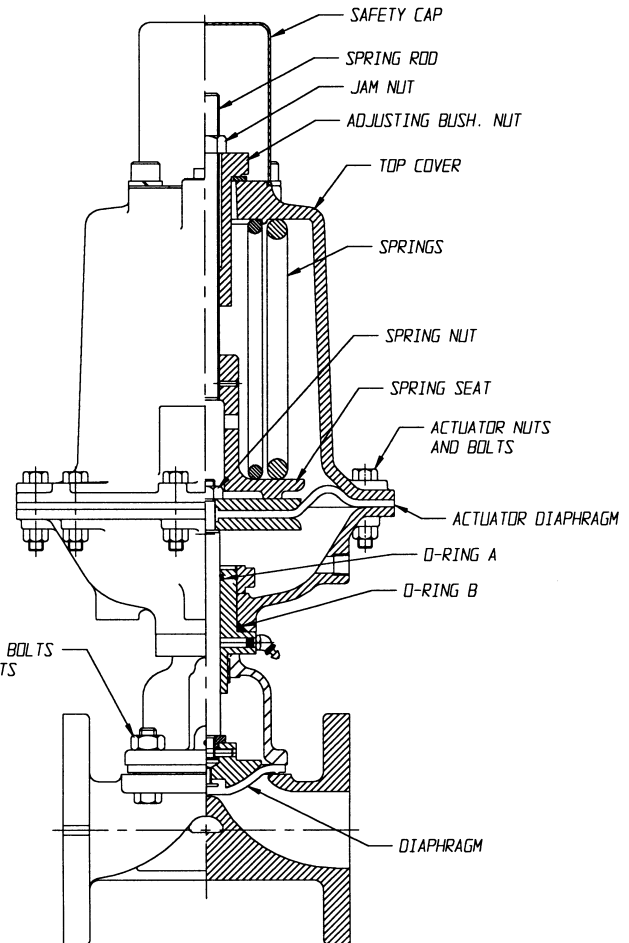

FIGURE 4(C)
3225

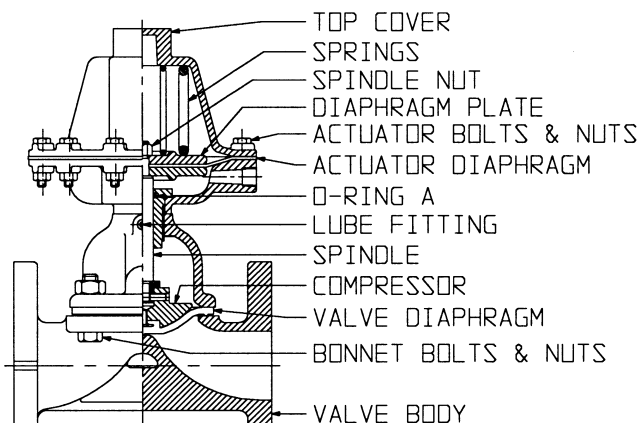
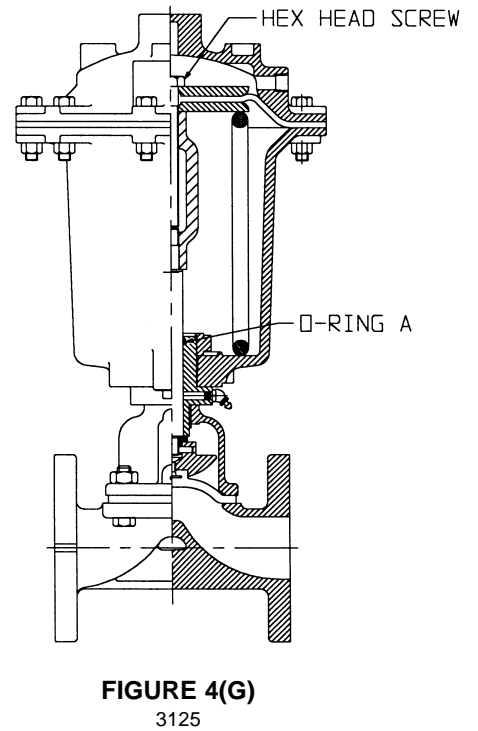
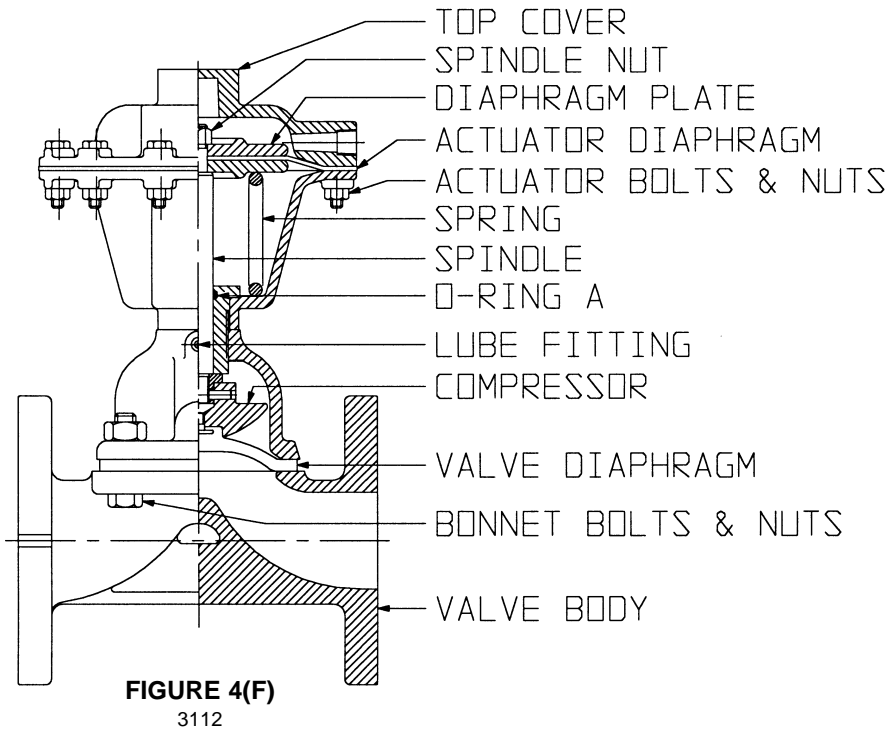
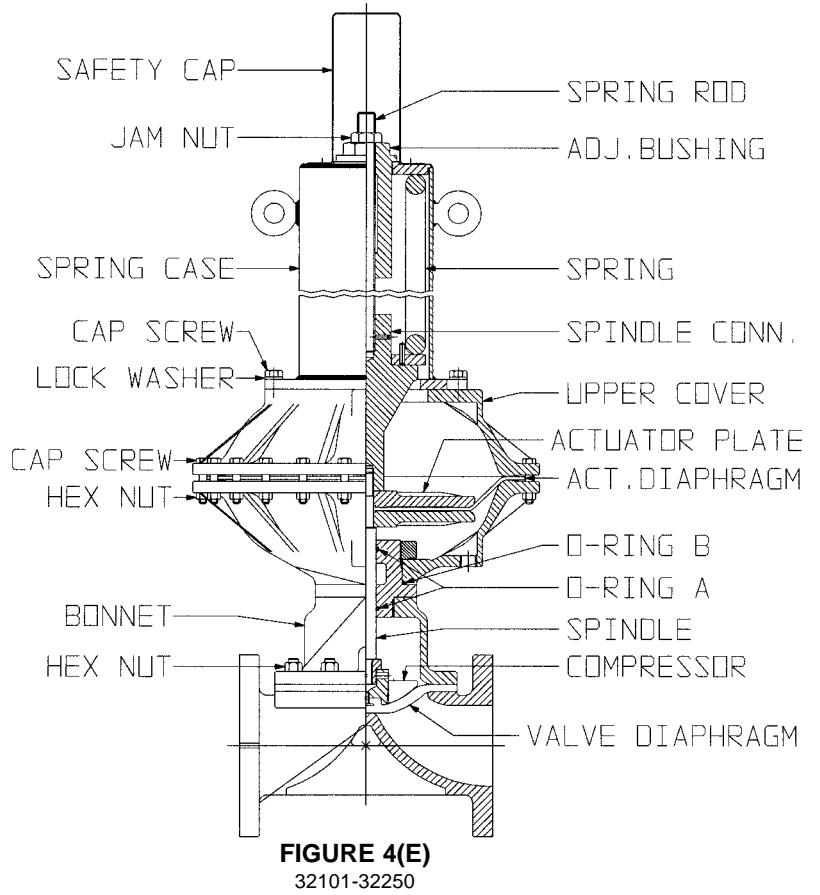
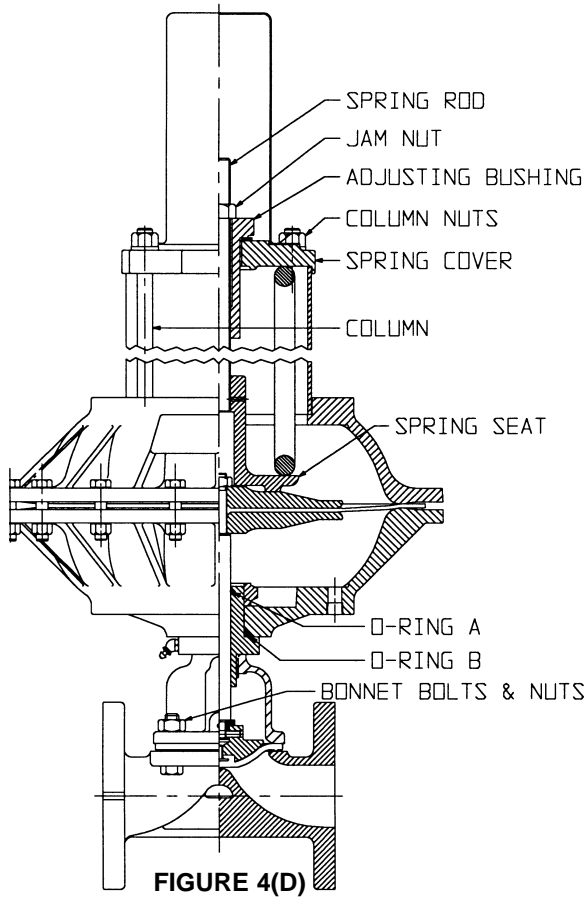

FIGURE 4(B)
3212



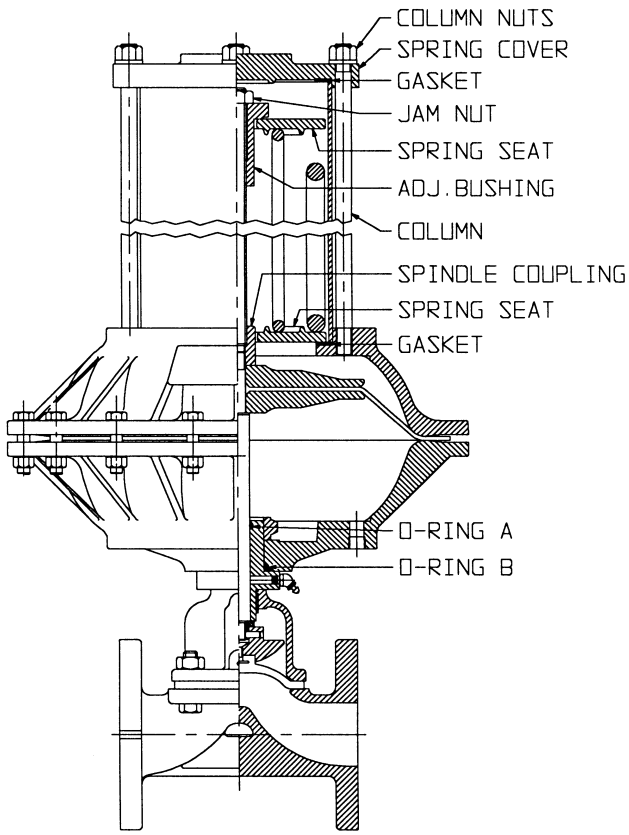

FIGURE 4(H)
3150

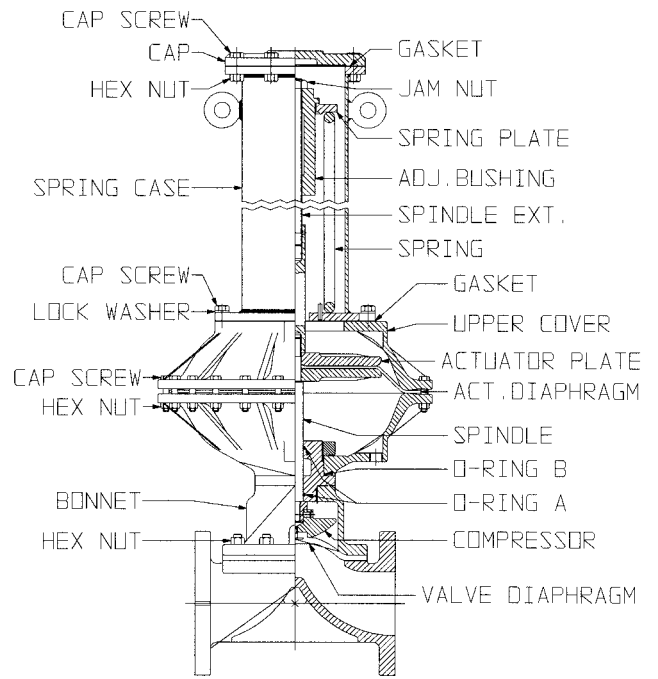

FIGURE 4(I)
31101-31250

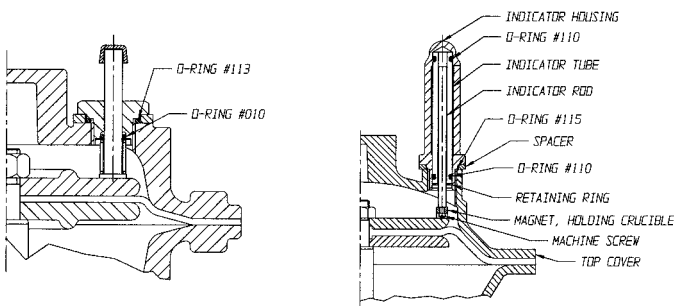

FIGURE 5(A)
3312
POSITION INDICATOR

FIGURE 5(B)
#25-#250
POSITION INDICATOR

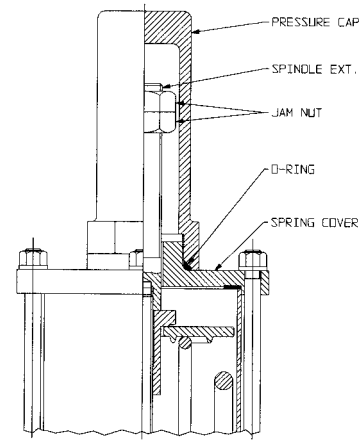

FIGURE 6
PRESSURE CAP & TRAVEL STOPS
3100 & 3300 SERIES

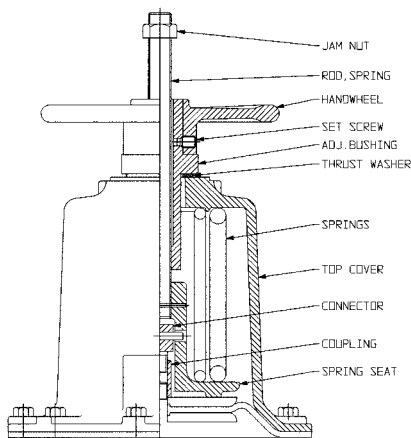

FIGURE 7
HANDWHEEL OPENING DEVICE
3200 SERIES

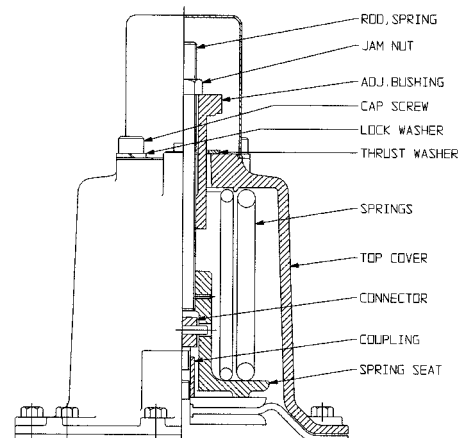

FIGURE 8
WRENCH OPENING DEVICE
3200 SERIES

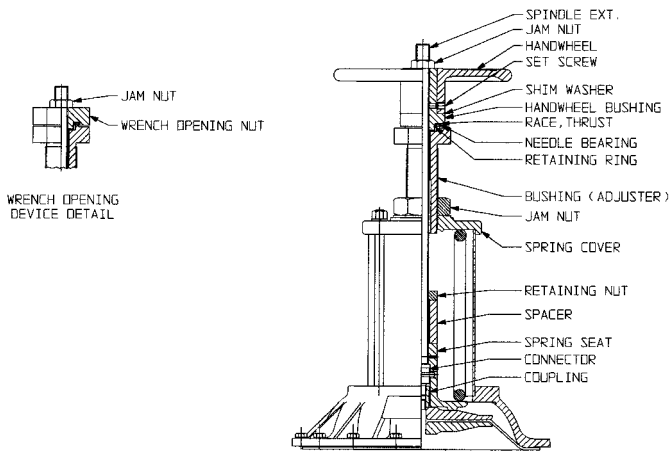

FIGURE 9(A)
COMBINATION WRENCH OR HANDWHEEL OPENING DEVICE
WITH ADJUSTABLE OPENING STOP
3225-32130

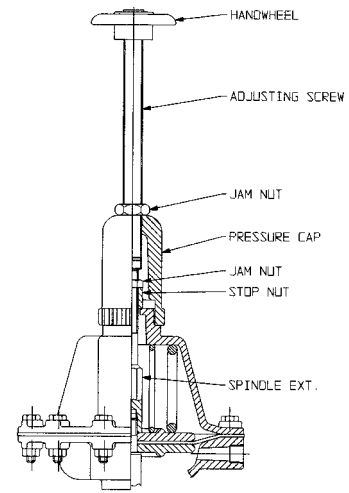

FIGURE 9(B)
COMBINATION WRENCH OPENING DEVICE AND
ADJUSTABLE OPENING STOP
3212

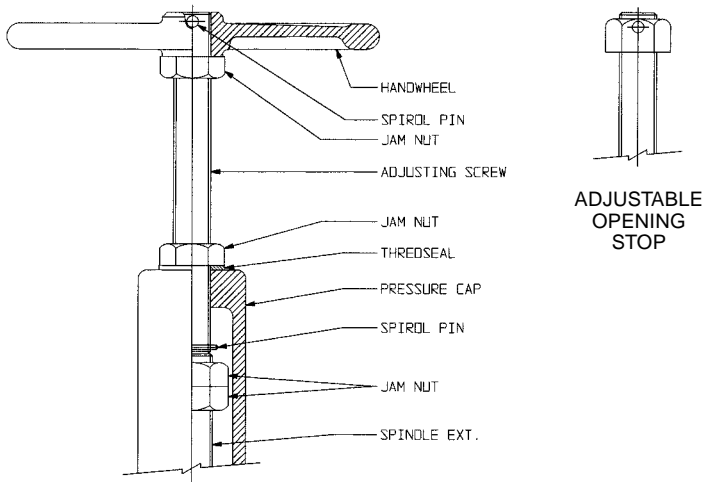

FIGURE 10
HANDWHEEL CLOSING DEVICE AND ADJUSTABLE OPENING STOP
3100 & 3300 SERIES

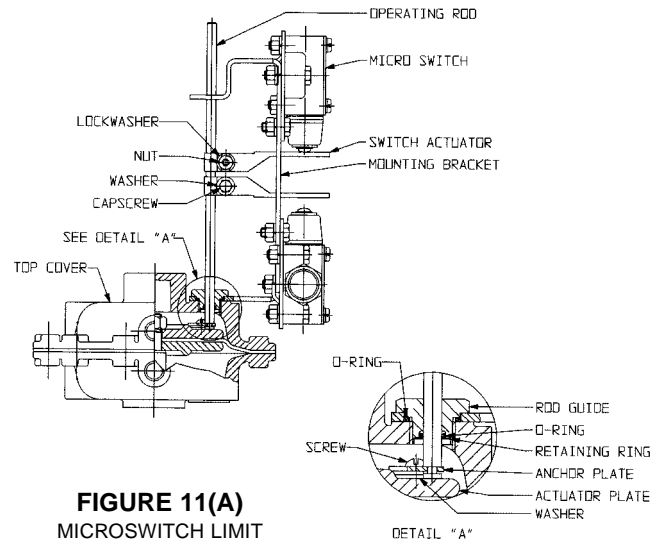

FIGURE 11(A)
MICROSWITCH LIMIT
SWITCHES
#12 ACTUATOR

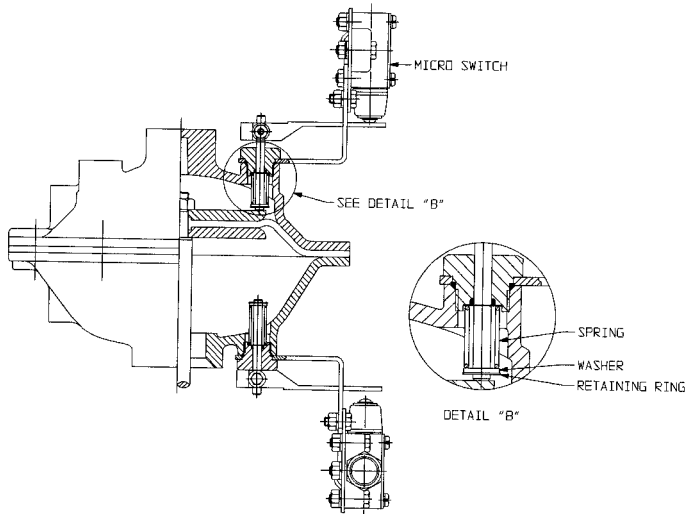

FIGURE 11(B)
MICROSWITCH LIMIT SWITCHES
#25-#250

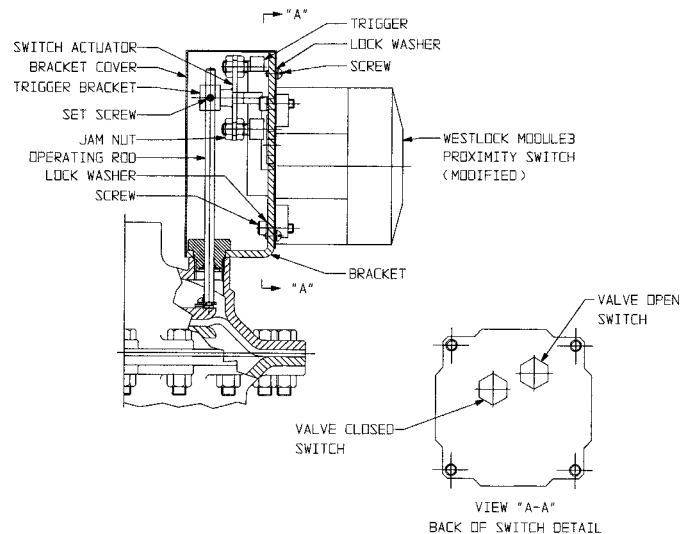

FIGURE 12
WESTLOCK MODULE 3 PROXIMITY SWITCH

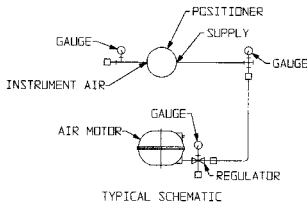
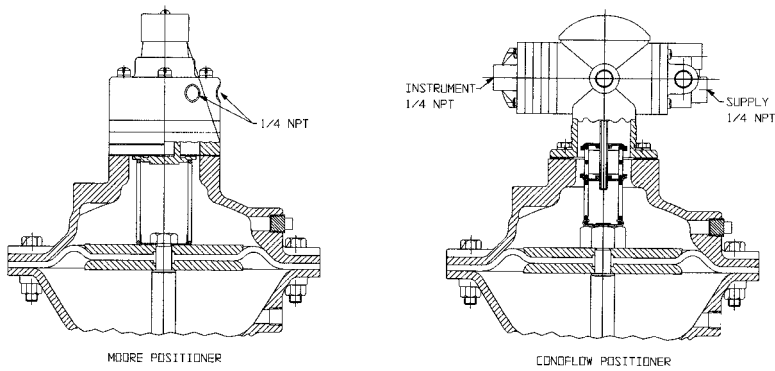

FIGURE 13

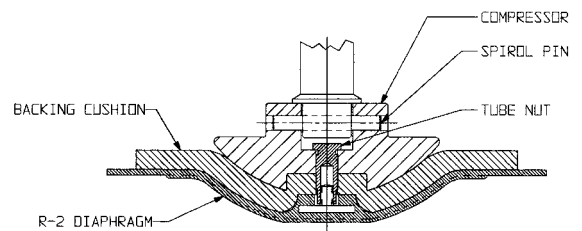
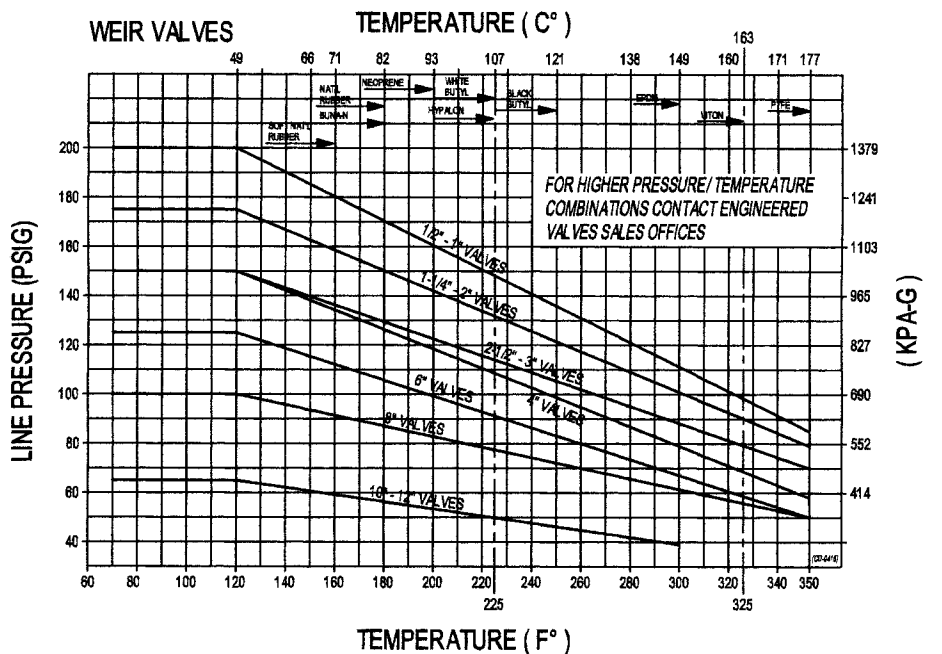
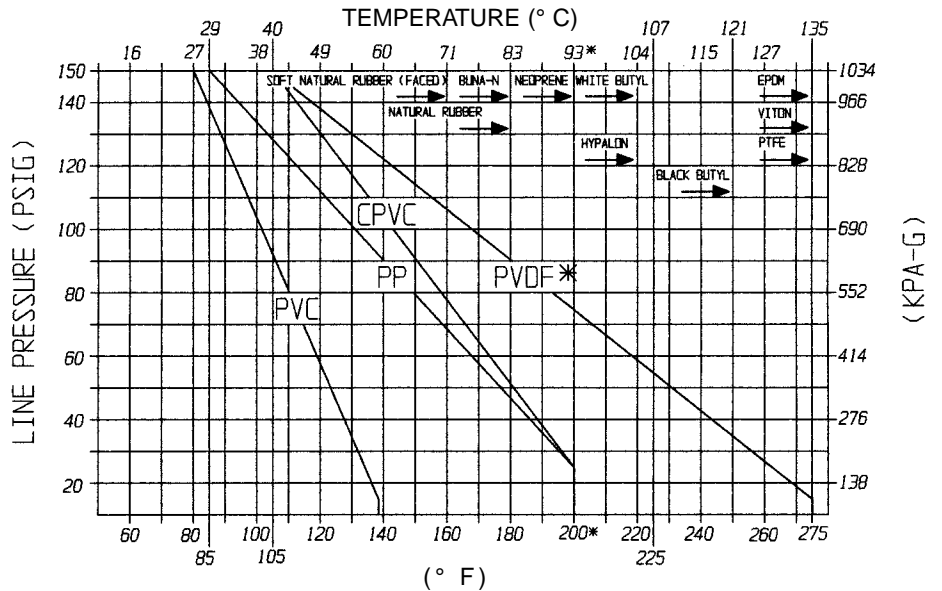

FIGURE 14
PLASTIC DIAPHRAGM DETAIL

DiaFlo® Diaphragm Valves

Weir Valve Pressure/Temperature Recommendations

- 1 - To find the maximum recommended operating temperature, enter the graph on the maximum operating temperature line.
- 2 - The intersection of temperature line with respective valve size curve determines the maximum recommended operating pressure, read at left of the graph.
- 3 - Maximum recommended operating temperature may be determined by knowing the maximum operating pressure and reversing the above procedure.
- 4 - Operating pressure and temperature combinations above respective valve size curves should be avoided for maximum diaphragm flex-life.
- 5 - Maximum temperature limitations of various diaphragm materials are also indicated by arrows under diaphragm material.



Note: Maximum pressure rating for Dualrange Control Valves is 100 psi.

*PAS bonnet required above 200°F (93°C)

Industrial Group

For more information write to:

Engineered Valves Headquarters
33 Centerville Road, P.O. Box 6164
Lancaster, PA 17603-2064 USA
or call: (800) 366-1111
(717) 509-2200

Fax: (717) 509-2336
Website: www.engvalves.com
E-mail: engvalves_custserv@fluids.ittind.com

REGIONAL OFFICES

ATLANTIC - USA

Phone 800-231-0328
Phone (717) 509-2200
Fax 800-231-0330
Fax (717) 509-2336

CENTRAL - USA

Phone 800-366-4770
Phone (717) 509-2200
Fax 800-231-0330
Fax (717) 509-2336

PACIFIC - USA

725 E. Cochran Street, Unit E
Simi Valley, CA 93065
Phone 800-926-8884
Phone (805) 520-7200
Fax (805) 520-7205

SOUTH AMERICA

Av. 11 de Septiembre #1363
Of. 1403 Providencia
Santiago - Chile
Phone +56-2-264-9491 (9637)
Fax +56-2-236-1799

MEXICO

Insurgentes Sur No. 600-4°P
Co. Del Valle
C.P. 03100 Mexico D.F.
Phone +52-5-669-5002
Fax +52-5-669-5289

PUERTO RICO

P.O. Box 1225
Hato Rey, PR 00919
Phone/Fax (787) 703-0402

EUROPE

Richards Street
Kirkham, Lancashire
PR4 2HU, England
Phone +44-1772-682696
Fax +44-1772-686006

HONG KONG

Ground Floor, Times Tower
928 Cheung Sha Wan Road
Kowloon, Hong Kong
Phone +852-2741-6302
Fax +852-2741-6605

