



Industrial Process  
33 Centerville Road  
Lancaster, PA 17603  
Tel 717.509.2200  
Fax 717.509.2336

## **Pure-Flo**

### **Topworks Option “S” – Sealed**

**August 2010**

## Introduction

Users should consider the use of a sealed bonnet when process involves hazardous or corrosive material. A sealed bonnet provides a secondary containment area for process fluids if the diaphragm should ever fail. The special “V” notch vent plug serves as a leak detector and prevents the release of process fluids into the atmosphere.

Sealed bonnets also minimize maintenance and cleaning issues when valves are subjected to Clean out of Place (COP) and Sterilize out of Place protocols common to the Biopharm industry.

## Safety

Sealed bonnets are rated to 100% of valve pressure rating and allow leak detection under controlled conditions. The V-notch vent design allows the user a method to safely inspect for diaphragm failure when the free release of the process fluid could be hazardous or potentially damaging to personnel and property.

## Cleaning and Sterilizing Out of Place

Valves subjected to Clean out of Place (COP) protocols benefit from bonnet sealing by preventing the ingress of fluids into the valve bonnet during external wash down or submersion cleaning (please note valve must be fully assembled).

Sealed bonnets are also beneficial when utilized on valve top works that are subjected to Sterilizing out of Place (SOP) i.e. autoclaving. Sealed bonnets prevent the formation of condensation in the bonnet assembly during the heating and cooling of the sterilization process. This in turn prevents unwanted residual fluids in or around the process and minimizes sterilization effort.

Sealed bonnets are an available option on most manual and automated Pure-Flo valve assemblies.

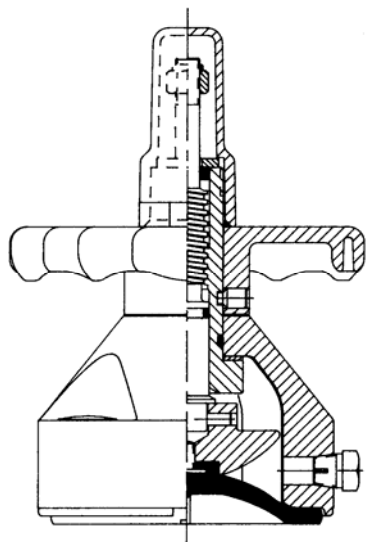

Sealed bonnet – V-notch vent plug

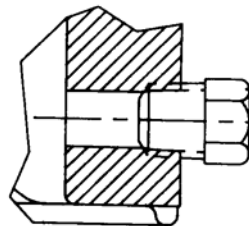

V-notch vent plug detail