



# ITT

## Industrial Process

---

# Installation and Operation Manual

### Value Switch Package (VSP)



*Engineered for life*



---





# Table of Contents

<b>Introduction and Safety</b> .....	2
Safety message levels.....	2
User health and safety.....	2
<b>Transportation and storage</b> .....	4
Handling and unpacking guidelines.....	4
Storage, disposal, and return requirements.....	4
<b>Product Description</b> .....	5
General description.....	5
Switch identification.....	5
<b>Installation</b> .....	6
Mount the switch package on the actuator.....	6
<b>Operation</b> .....	7
Switch operation guidelines.....	7
<b>Maintenance</b> .....	8
Assemble the switch package.....	8
Set the switch.....	8
<b>Parts Listing and Cross-Sectional Drawings</b> .....	10
Drawing and parts.....	10
Wiring diagrams.....	11

# Introduction and Safety

## Safety message levels

### Definitions

Safety message level	Indication
 <b>DANGER:</b>	A hazardous situation which, if not avoided, will result in death or serious injury
 <b>WARNING:</b>	A hazardous situation which, if not avoided, could result in death or serious injury
 <b>CAUTION:</b>	A hazardous situation which, if not avoided, could result in minor or moderate injury
 <b>Electrical Hazard:</b>	The possibility of electrical risks if instructions are not followed in a proper manner
<b>NOTICE:</b>	<ul style="list-style-type: none"> <li>• A potential situation which, if not avoided, could result in an undesirable result or state</li> <li>• A practice not related to personal injury</li> </ul>

## User health and safety

### General precautions

This product is designed and manufactured using good workmanship and materials, and meets all applicable industry standards. This product should be used only as recommended by an IIT engineer.



#### **WARNING:**

- Misapplication of the valve can result in injury or property damage. Select valves and valve components of the proper materials and make sure that they are consistent with your specific performance requirements. Incorrect application of this product includes but is not limited to:
  - Exceeding the pressure or temperature rating
  - Failing to maintain this product according to the recommendations
  - Using this product to handle caustic or hazardous substances that it is not designed to handle

### Qualifications and training

The personnel responsible for the assembly, operation, inspection, and maintenance of the valve must be appropriately qualified. The operating company must do the following tasks:

- Define the responsibilities and competency of all personnel handling this equipment.
- Provide instruction and training.
- Ensure that the contents of the operating instructions have been fully understood by the personnel.

Instruction and training can be carried out by either IIT or the reseller of the valve by order of the operating company.

### Non-compliance risks

Failure to comply with all safety precautions can result in the following conditions:

- Death or serious injury due to electrical, mechanical, and chemical influences
- Environmental damage due to the leakage of dangerous materials

- Product damage
- Property damage
- Loss of all claims for damages

**Operational safety precautions**

Be aware of these safety precautions when operating this product:

- Do not leave hot or cold components of the product unsecured against contact if they are a source of danger.
- Do not remove the contact guard for moving parts when the product is in operation. Never operate the product without the contact guard installed.
- Do not hang items from the product. Any accessories must be firmly or permanently attached.
- Do not use the product as a step or hand hold.
- Do not paint over the identification tag, warnings, notices, or other identification marks associated with the product.

**Maintenance safety precautions**

Be aware of these safety precautions when performing maintenance on this product:

- You must decontaminate the product if it has been exposed to harmful substances such as caustic chemicals.
- You must immediately fit or reactivate all safety and protective equipment upon completion of work.

**Use of unauthorized parts**

Reconstruction or modification of the product is only permissible after consultation with ITT. Genuine spare parts and accessories authorized by ITT serve to maintain safety. Use of non-genuine ITT parts can annul liability of the manufacturer for the consequences. ITT parts are not to be used in conjunction with products not supplied by ITT as this improper use can annul all liability for the consequences.

**Unacceptable modes of operation**

The operational reliability of this product is only guaranteed when it is used as designated. The operating limits given on the identification tag and in the data sheet may not be exceeded under any circumstances. If the identification tag is missing or worn, contact ITT for specific instructions.

# Transportation and storage

## Handling and unpacking guidelines

---



**CAUTION:**

Always observe the applicable standards and regulations regarding the prevention of accidents when handling the product.

---

### Handling guidelines

Follow these guidelines when handling the product to prevent damage:

- Use care when handling the product.
- Leave protective caps and covers on the product until installation.

### Unpacking guidelines

Follow these guidelines when unpacking the product:

1. Inspect the package for damaged or missing items upon delivery.
2. Note any damaged or missing items on the receipt and freight bill.
3. If anything is out of order, file a claim with the shipping company.

## Storage, disposal, and return requirements

### Storage

If you are not immediately installing the product after delivery, store it as follows:

- Store the product in a dry room that maintains a constant temperature.
- Make sure that the products are not stacked on top of one another.

### Disposal

Dispose of this product and associated components in compliance with federal, state, and local regulations.

### Return

Ensure these requirements are met before you return a product to ITT:

- Contact ITT for specific instructions on how to return the product.
- Clean the valve of all hazardous material.
- Complete a Material Safety Data Sheet or Process Data Sheet for any process fluid that could remain on the valve.
- Obtain a Return Material Authorization from the factory.

# Product Description

## General description

The switch package is offered with a complete range of mechanical switches and proximity sensors to meet your electrical and control system specifications. The switch package can be mounted on the Advantage and Advantage Piston Actuator lines of pneumatic actuation.

## Switch identification

### Switch labels

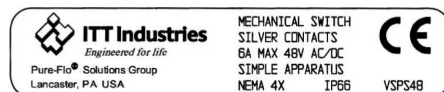

Figure 1: VSPS48

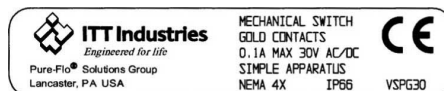

Figure 2: VSPG30

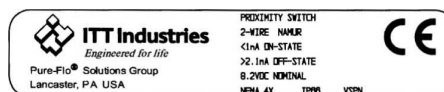

Figure 3: VSPN

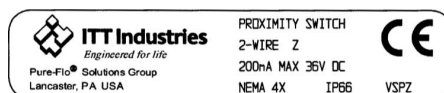

Figure 4: VSPZ

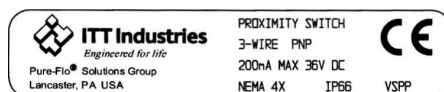

Figure 5: VSPPP

### Switch type

Code	Type	Description
VSPS48	Mechanical	3 wire, silver contacts 48V
VSPG30	Mechanical	3 wire, gold contacts 30V
VSPN	Proximity	2 wire Namur (NC output)
VSPZ	Proximity	2 wire "Z" (NO/NC programmable)
VSPPP	Inductive proximity	3 wire (PNP, NO output)

# Installation

## Mount the switch package on the actuator

1. Prepare the actuator for the switch:
    - a) Remove the four stainless steel screws on the actuator upper cover.
    - b) Place the valve in the open position.
    - c) Remove the plastic plug from the indicating spindle.
  2. Slide the switch sub-assembly off the switch adapter.
- 

**NOTICE:**

Do not damage the switch internals (specifically the mechanical switch levers).

---

3. Slip the switch actuator spindle through the switch adapter until the #10-24 UNC threads are exposed.
  4. Apply Blue Loctite #242 to the #10-24 UNC threads.
  5. Thread the switch actuator spindle into the indicating spindle until it shoulders.
  6. Secure the switch adapter to the actuator upper cover by tightening the four hex socket head screws to 5 in-lbs (0.56 N-m).
  7. Slide the switch sub assembly down over the switch adapter and position the conduit entrance in the desired position.
- 

**NOTICE:**

Do not damage the switch internals (specifically the mechanical switch levers).

---

8. Press down on the switch sub assembly and tighten the set screw located on the side of the lower housing to lock the unit in place.

The switch adapter has two molded counterbores. Locating the set screw in one of these holes provides maximum resistance to rotation.

The set screw torque should not exceed 5 in-lbs (0.56 N-m).

9. Remove the switch package upper cover.
10. Run field wires and conduit to the switch package.

For more information, see the Wiring diagrams in this manual.
11. Verify that the switches operate correctly by cycling the valve.

For more information, see Set the switch in this chapter.
12. Push the terminal strip on the bracket assembly down until the top of the terminal strip is approximately flush with the top of the mating bracket.
13. Screw on the switch package upper cover.

Ensure the o-ring remains in the groove.

# Operation

## Switch operation guidelines

- The switch package is not autoclavable.
- Maximum switch temperature is 140°F (60°C).
- Switches and positioners cannot be used together.
- For switch package models containing mechanical snap switches, contact “bounce” may occur during operation. This characteristic can be eliminated through electrical filters or software. Contact IIT for more information.

# Maintenance

## Assemble the switch package

These instructions are for assembling the switch package after service or repair.

Ensure all o-rings are on the switch adapter and lubricated with Dow 111.

1. Slip the switch actuator spindle through the switch adapter until the #10-24 UNC threads are exposed.
2. Apply Blue Loctite #242 to the #10-24 UNC threads.
3. Thread the switch actuator spindle into the indicating spindle until it shoulders.
4. Secure the switch adapter to the actuator upper cover by tightening the four hex socket head screws to 5 in-lbs (0.56 N-m).
5. Thread the appropriate switch actuator(s) on to the switch actuator spindle.
6. Position the closed switch actuator approximately 0.14 in. (3.6 mm or 4 turns) from end of threads and position the open switch actuator approximately 0.25 in. (6.4 mm or 7 turns) below the top of the switch actuator spindle.

Do not tighten the set screw.

7. Remove the switch package upper cover.
8. Slide the switch sub-assembly down over the switch adapter and position the conduit entrance in the most desirable location.

---

### NOTICE:

Do not damage the switch internals (specifically the mechanical switch levers).

- 
9. Press down on the switch sub assembly and tighten the set screw located on the side of the lower housing to lock the unit in place.

The switch adapter has two molded counterbores. Locating the set screw in one of these holes provides maximum resistance to rotation.

The set screw torque should not exceed 5 in-lbs. (0.56 N-m).

10. Run field wires and conduit to the switch package.  
For more information, see the Wiring diagrams in this manual.
11. Verify the switches operate correctly by cycling the valve.  
For more information, see Set the switch in this chapter.
12. Push the terminal strip down until the top of the terminal strip is approximately flush with the top of the mating bracket.
13. Screw on the switch package upper cover.  
Ensure the o-ring remains in the groove.

## Set the switch



---

### CAUTION:

Do not short the inductive proximity switch by directly connecting a power supply. Irreparable and immediate damage can occur to the switch.

---

### NOTICE:

The closed switch actuator must never hit the adapter in the closed position with the body attached.

The switch package is pre-set at the factory. Only minimal adjustment is required to adapt to the actuator.

1. Remove the switch package upper cover.
2. Verify that the switch package locking set screw is tight.

3. Place the valve in full open position.
4. Connect the appropriate test device to the open switch terminals.

Switch type	Test device
Mechanical	Traditional volt meter
Proximity	Inductive proximity tester (ex. Pepperl+Fuch's model #1-1305)
Inductive proximity	Energize with correct load and supply voltage

5. Thread the upper switch actuator two turns past the initial switch indication and lock it in place with the set screw on the switch actuator.
6. Place the valve in the full closed position and connect the appropriate test device to the closed switch terminals.

Switch type	Test device
Mechanical	Traditional volt meter
Proximity	Inductive proximity tester (ex. Pepperl+Fuch's model #1-1305)
Inductive proximity	Energize with correct load and supply voltage

7. Thread the lower switch actuator two turns past the initial switch indication and lock it in place with the set screw on the switch actuator.
8. Replace the switch package upper cover.

# Parts Listing and Cross-Sectional Drawings

## Drawing and parts

List of parts

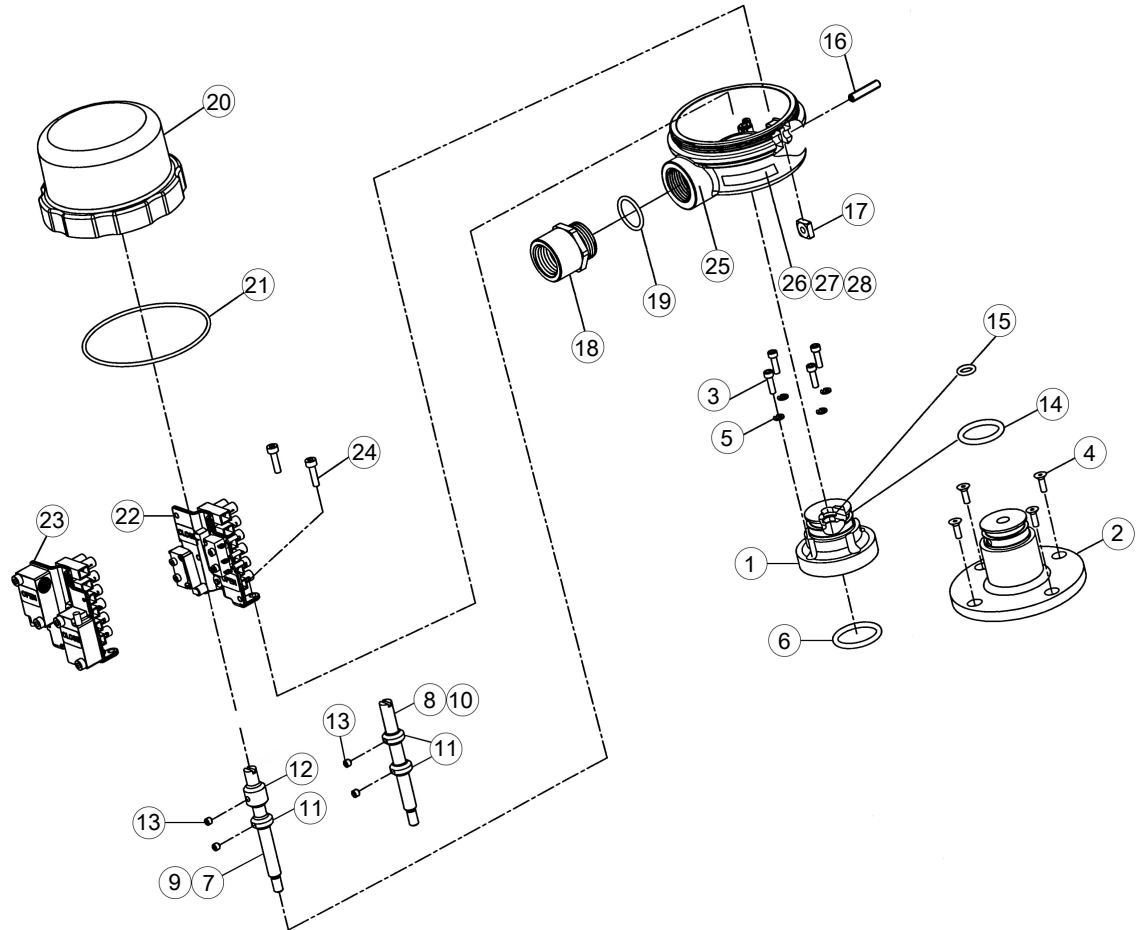

Figure 6:

Item	Description	Material	Quantity
1 <sup>1</sup>	Adapter, Bio-Tek - 1 in. actuator	Plastic	1
2 <sup>2</sup>	Adapter, 1 1/2 - 2 in. actuator	Plastic	1
3 <sup>3 1</sup>	Cap screw, hex socket head	Stainless steel	4
4 <sup>2 3</sup>	Machine screw, hex socket head	Stainless steel	4
5 <sup>1</sup>	Washer, Lock	Stainless steel	4
6	O-ring #117	Buna-N	1
7 <sup>1 4</sup>	Switch actuator spindle	Stainless steel	1
8 <sup>2 5</sup>	Switch actuator spindle	Stainless steel	1
9 <sup>1 6</sup>	Switch actuator spindle	Stainless steel	1

- <sup>1</sup> Bio-Tek through 1 in. actuators only
- <sup>2</sup> 1.5 in. and 2 in. actuators only
- <sup>3</sup> Torque fasteners to 4-6 in-lb (0.45-0.68 N-m)
- <sup>4</sup> Use with Bio-Tek, 0.5 in., 0.75 in. valve
- <sup>5</sup> Use with 1.5 in. valve
- <sup>6</sup> Use with 1 in. valve

Item	Description	Material	Quantity
10 <sup>2 7</sup>	Switch actuator spindle	Stainless steel	1
11	Actuator switch T1	Stainless steel	As required
12	Actuator switch T2	Stainless steel	As required
13 <sup>8</sup>	Set screw	Stainless steel	2
14	O-ring #116, external groove	Buna-N	1
15	O-ring #110, internal groove	Buna-N	1
16 <sup>9</sup>	Set screw	Stainless steel	1
17	Square nut	Stainless steel	1
18	Adapter 1/2" - NPT	Nickel-plated brass	1
19	O-ring #16	Buna-N	1
20	Upper cover	Plastic	1
21	O-ring #037	Buna-N	1
22	Bracket assembly mechanical	Stainless steel	1
23	Bracket assembly proximity	Stainless steel	1
24 <sup>3</sup>	Cap screw, hex socket head	Stainless steel	2
25	Lower housing	Plastic	1
26	North American label	Mylar	As required
27	European label	Mylar	As required
28	Far side only label warning	Mylar	As required

- Stake all fasteners with Loctite Blue #242
- Lubricate all o-rings with Dow #111

## Wiring diagrams

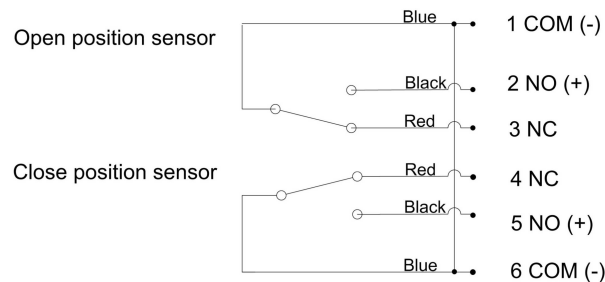

**Figure 7: VS48 – 3 wire mechanical switch (silver contacts)**

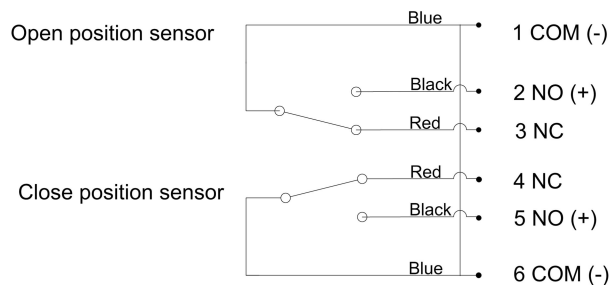
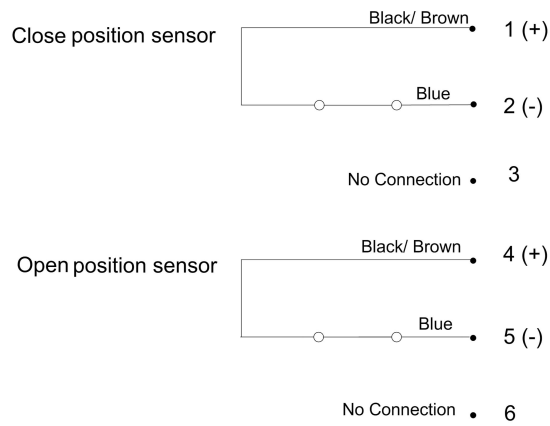

**Figure 8: VSPG30 – 3 wire mechanical switch (gold contacts)**

<sup>7</sup> Use with 2 in. valve

<sup>8</sup> Orient toward item 18

<sup>9</sup> Torque should not exceed 5 in-lb (0.56 N-m)



**Figure 9: VSPN – 2 wire NAMUR proximity switch (NC output)**

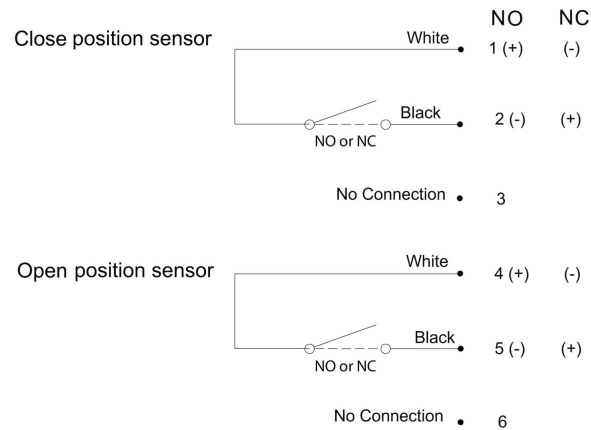

**Figure 10: VSPZ – 2 wire "Z" proximity switch (NO/NC programmable)**

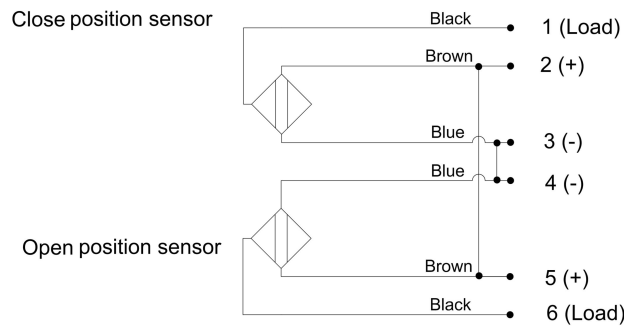

**Figure 11: VSP - 3 wire inductive proximity switch (PNP, NO output)**





# ITT

Visit our Web site for the latest version of this document and more information  
[www.ittpureflo.com](http://www.ittpureflo.com)

---

ITT Pure-Flo  
33 Centerville Road  
Lancaster, PA 17603  
USA  
Tel. +1-717-509-2200  
Fax +1-717-509-2316  
E-mail: [pureflo.custserv@itt.com](mailto:pureflo.custserv@itt.com)

ITT Pure-Flo  
Richards Street, Kirkham  
Lancashire PR4 2HU  
England  
Tel. +44-1772-682696  
Fax +44-1772-686006