

VALVE END	DIM'S	CROSS TUBE							
		0.75 [19,0]	1.00 [25,4]	1.50 [38,1]	2.00 [50,8]	2.50 [63,5]	3.00 [76,2]	4.00 [101,6]	
0.75 [DN20]	'A'	5.75 [146,0]	5.75 [146,0]	5.75 [146,0]	6.25 [158,8]	6.25 [158,8]	6.25 [158,8]	6.75 [171,4]	
	'B'	1.50 [38,1]	1.50 [38,1]	1.50 [38,1]	1.75 [44,4]	1.75 [44,4]	1.75 [44,4]	2.00 [50,8]	
	'C'	3.25 [82,6]	3.38 [85,9]	3.65 [92,7]	3.91 [99,3]	4.17 [105,9]	4.43 [112,5]	4.95 [125,7]	
	'D'	1.50 [38,1]	1.50 [38,1]	1.50 [38,1]	1.50 [38,1]	1.50 [38,1]	1.50 [38,1]	1.50 [38,1]	
	'E'	0.26 [6,6]	0.46 [11,7]	0.73 [18,5]	0.93 [23,6]	1.09 [27,7]	1.23 [31,2]	1.68 [42,7]	
	'F'	3.75 [95,2]	5.00 [127,0]	5.00 [127,0]	5.00 [127,0]	5.00 [127,0]	5.00 [127,0]	5.00 [127,0]	
	'H'	0.50 [12,7]	1.12 [28,4]	1.12 [28,4]	1.12 [28,4]	1.12 [28,4]	1.12 [28,4]	1.12 [28,4]	
	'J'	2.25 [57,2]	2.38 [60,5]	2.65 [67,3]	2.91 [73,9]	3.17 [80,5]	3.43 [87,1]	3.95 [100,3]	
	'K'	0.50 [12,7]	0.50 [12,7]	0.50 [12,7]	0.50 [12,7]	0.50 [12,7]	0.50 [12,7]	0.50 [12,7]	
	'L'	0.47 [11,9]	0.58 [14,7]	0.53 [13,5]	0.88 [22,4]	1.18 [30,0]	1.62 [41,1]	2.40 [61,0]	
	'M'	2.19 [55,6]	2.32 [58,9]	2.59 [65,8]	2.84 [72,1]	3.09 [78,5]	3.34 [84,8]	3.83 [97,3]	
	'N'	1.75 [44,5]	1.74 [44,2]	1.75 [44,3]	1.76 [44,6]	1.76 [44,6]	1.78 [45,2]	1.80 [45,7]	
	'P'	0.70 [17,8]	0.89 [22,6]	1.17 [29,7]	1.36 [34,6]	1.53 [38,9]	1.67 [42,4]	2.11 [53,6]	
	1.00 [DN25]	'A'	6.14 [156,0]	6.14 [156,0]	6.64 [168,7]	6.64 [168,7]	6.64 [168,7]	7.14 [181,4]	
'B'		1.50 [38,1]	1.50 [38,1]	1.75 [44,4]	1.75 [44,4]	1.75 [44,4]	2.00 [50,8]		
'C'		3.63 [92,2]	3.90 [99,1]	4.16 [105,7]	4.42 [112,3]	4.68 [118,9]	5.19 [131,8]		
'D'		1.50 [38,1]	1.50 [38,1]	1.50 [38,1]	1.50 [38,1]	1.50 [38,1]	1.50 [38,1]		
'E'		0.28 [7,1]	0.59 [15,0]	0.81 [20,6]	0.98 [24,9]	1.15 [29,2]	1.44 [36,6]		
'F'		5.38 [136,7]	5.38 [136,7]	5.38 [136,7]	5.38 [136,7]	5.38 [136,7]	5.38 [136,7]		
'H'		1.12 [28,4]	1.12 [28,4]	1.12 [28,4]	1.12 [28,4]	1.12 [28,4]	1.12 [28,4]		
'J'		3.25 [82,6]	3.52 [89,4]	3.78 [96,0]	4.04 [102,6]	4.30 [109,2]	4.81 [122,2]		
'K'		1.12 [28,4]	1.12 [28,4]	1.12 [28,4]	1.12 [28,4]	1.12 [28,4]	1.12 [28,4]		
'L'		0.63 [16,0]	0.88 [22,4]	0.65 [16,5]	0.92 [23,4]	1.24 [31,5]	1.73 [43,9]		
'M'		2.52 [64,0]	2.78 [70,6]	3.05 [77,5]	3.31 [84,1]	3.56 [90,4]	4.05 [102,9]		
'N'		1.99 [50,5]	2.00 [50,8]	1.99 [50,5]	1.99 [50,5]	2.00 [50,8]	2.02 [51,3]		
'P'		0.96 [24,4]	1.26 [32,0]	1.48 [37,6]	1.65 [41,9]	1.82 [46,2]	2.11 [53,6]		
1.50 [DN40]		'A'	7.25 [184,2]	7.75 [196,8]	7.75 [196,8]	7.75 [196,8]	8.25 [209,6]		
	'B'	1.50 [38,1]	1.75 [44,4]	1.75 [44,4]	1.75 [44,4]	2.00 [50,8]			
	'C'	4.46 [113,3]	4.73 [120,1]	4.99 [126,7]	5.25 [133,4]	5.76 [146,3]			
	'D'	1.50 [38,1]	1.50 [38,1]	1.50 [38,1]	1.50 [38,1]	1.50 [38,1]			
	'E'	0.23 [5,8]	0.55 [13,9]	0.79 [20,1]	0.99 [25,1]	1.32 [33,5]			
	'F'	6.25 [158,8]	6.25 [158,8]	6.25 [158,8]	6.25 [158,8]	6.25 [158,8]			
	'H'	1.00 [25,4]	1.00 [25,4]	1.00 [25,4]	1.00 [25,4]	1.00 [25,4]			
	'J'	4.08 [103,6]	4.35 [110,5]	4.61 [117,1]	4.87 [123,7]	5.38 [136,7]			
	'K'	1.12 [28,4]	1.12 [28,4]	1.12 [28,4]	1.12 [28,4]	1.12 [28,4]			
	'L'	0.75 [19,0]	0.88 [22,4]	0.88 [22,4]	0.99 [25,1]	1.28 [32,5]			
	'M'	3.35 [85,1]	3.63 [92,2]	3.90 [99,1]	4.16 [105,7]	4.66 [118,4]			
	'N'	2.54 [64,5]	2.54 [64,5]	2.53 [64,3]	2.53 [64,3]	2.54 [64,5]			
	'P'	1.26 [32,0]	1.58 [40,1]	1.82 [46,2]	2.02 [51,3]	2.35 [59,7]			
	2.00 [DN50]	'A'	8.75 [222,2]	8.75 [222,2]	8.75 [222,2]	9.25 [235,0]			
'B'		1.75 [44,4]	1.75 [44,4]	1.75 [44,4]	2.00 [50,8]				
'C'		5.28 [134,1]	5.55 [141,0]	5.82 [147,8]	6.32 [160,5]				
'D'		1.75 [44,4]	1.75 [44,4]	1.75 [44,4]	1.75 [44,4]				
'E'		0.28 [7,1]	0.59 [15,0]	0.83 [21,1]	1.21 [30,7]				
'F'		7.00 [177,8]	7.00 [177,8]	7.00 [177,8]	7.00 [177,8]				
'H'		0.88 [22,4]	0.88 [22,4]	0.88 [22,4]	0.88 [22,4]				
'J'		4.66 [118,4]	4.93 [125,2]	5.19 [131,8]	5.70 [144,8]				
'K'		1.12 [28,4]	1.12 [28,4]	1.12 [28,4]	1.12 [28,4]				
'L'		0.97 [24,6]	1.00 [25,4]	1.03 [26,2]	1.01 [25,7]				
'M'		3.93 [99,8]	4.20 [106,7]	4.47 [113,5]	4.99 [126,7]				
'N'		3.05 [77,5]	3.04 [77,2]	3.03 [77,0]	3.02 [76,7]				
'P'		1.60 [40,6]	1.92 [48,8]	2.15 [54,6]	2.54 [64,5]				

LIST OF MAJOR COMPONENTS			
ITEM	DESCRIPTION	MATERIAL	QTY
1	BODY-ZSBBS	SS 316L	1
2	TUBING-CROSS TUBE END 16	SS 316L	AR
3	TUBING-VALVE END 16G	SS 316L	1
4	FERRULE-CROSS TUBE END TC	SS 316L	AR
5	FERRULE-VALVE END TC	SS 316L	1
6	STUD		4
7	FERRULE-SAMPLE PORT END TC 00.50 x 01.12	SS 316L	1
	FERRULE-REDUCING SAMPLE PORT END TC 00.50 x 01.12	SS 316L	1

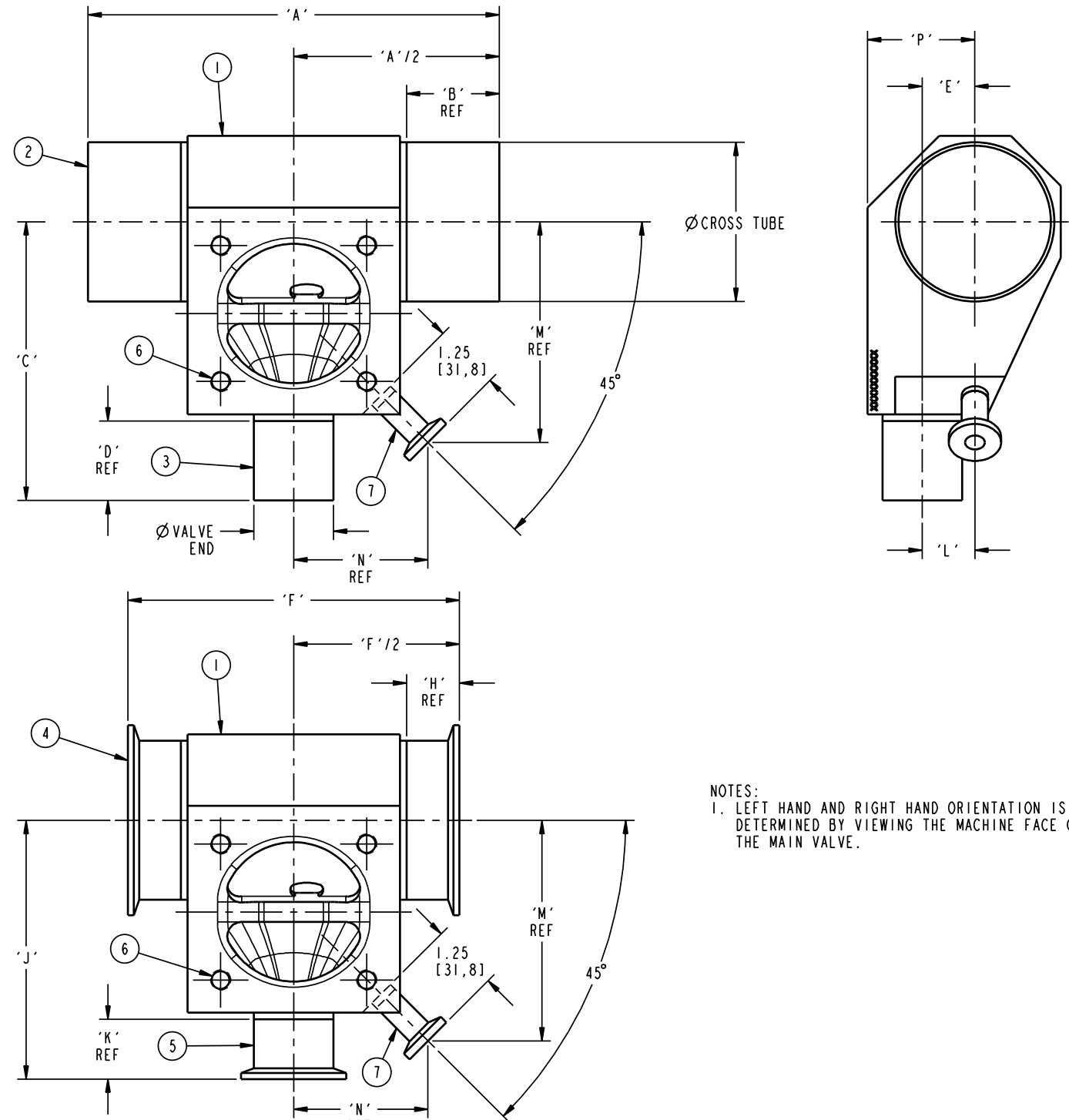

RIGHT HAND ORIENTATION SHOWN
SEE NOTE 1

NOTES:
1. LEFT HAND AND RIGHT HAND ORIENTATION IS DETERMINED BY VIEWING THE MACHINE FACE OF THE MAIN VALVE.

P1 P2 P3 P4
PURE-FLO ORDER: _____ ITEM: _____
CUSTOMER: _____
CUSTOMER PO: _____
OTHER INFO: _____
ISSUED BY: _____ CERTIFIED BY: _____

THIS DOCUMENT IS THE SOLE PROPERTY OF ITT INDUSTRIES, INC., OR ITS SUBSIDIARY, AND IS PROVIDED SUBJECT TO RETURN. IT IS ISSUED IN STRICT CONFIDENCE AND SHALL NOT BE REPRODUCED, OR COPIED, OR DISCLOSED IN WHOLE OR IN PART, OR USED AS THE BASIS FOR THE MANUFACTURE OR SALES OF APPARATUS OR PARTS TO WHICH THE DOCUMENT RELATES, WITHOUT THE EXPRESS WRITTEN CONSENT OF ITT INDUSTRIES, INC., OR ITS SUBSIDIARY. THIS LEGEND SHALL BE MARKED ON ANY REPRODUCTION HEREOF, IN WHOLE OR IN PART. ALL RIGHTS TO THE INFORMATION AND DESIGN DISCLOSED HEREIN ARE RESERVED TO ITT INDUSTRIES, INC., OR ITS SUBSIDIARY.

THIRD ANGLE PROJECTION
UNLESS OTHERWISE SPECIFIED, ALL DIMENSIONS ARE IN INCHES

UNLESS OTHERWISE NOTED
INCH MM
X: ±0.06 ±0.15
XX: ±0.06 ±0.15
XXX: ±0.02 ±0.05
1/2: ±0.01 ±0.02
1/16: ±0.005 ±0.01

DATE	BY	STANDARDS-ZSBBS
11/11/04	JWP	WEIR 00.75 - 02.00
11/11/04	JRD	
11/11/04	JRD	

WT: - ECN# 8555 MASTER DWG 008731

ITT Pure-Flo
www.ittpureflo.com
SITE PA D 008731 REV -
SHEET 1 OF 1