

VALVE END	DIM'S	CROSS TUBE							
		0.75 [19,0]	1.00 [25,4]	1.50 [38,1]	2.00 [50,8]	2.50 [63,5]	3.00 [76,2]	4.00 [101,6]	
0.75 [DN20]	'A'	5.00 [127,0]	6.12 [155,4]	8.50 [215,9]	11.00 [279,4]	12.50 [317,5]	14.00 [355,6]	17.00 [431,8]	
	'B'	3.00 [76,2]	3.00 [76,2]	3.75 [95,2]	4.75 [120,6]	5.50 [139,7]	6.25 [158,8]	8.00 [203,2]	
	'C'	3.25 [82,6]	3.38 [85,9]	3.65 [92,7]	3.91 [99,3]	4.17 [105,9]	4.43 [112,5]	4.95 [125,7]	
	'D'	1.50 [38,1]	1.50 [38,1]	1.50 [38,1]	1.50 [38,1]	1.50 [38,1]	1.50 [38,1]	1.50 [38,1]	
	'E'	0.26 [6,6]	0.46 [11,7]	0.73 [18,5]	0.93 [23,6]	1.09 [27,7]	1.23 [31,2]	1.68 [42,7]	
	'F'	2.25 [57,2]	2.38 [60,5]	2.65 [67,3]	2.91 [73,9]	3.17 [80,5]	3.43 [87,1]	3.95 [100,3]	
	'H'	0.50 [12,7]	0.50 [12,7]	0.50 [12,7]	0.50 [12,7]	0.50 [12,7]	0.50 [12,7]	0.50 [12,7]	
	'J'	0.47 [11,9]	0.58 [14,7]	0.53 [13,5]	0.88 [22,4]	1.18 [30,0]	1.62 [41,1]	2.40 [61,0]	
	'K'	2.19 [55,6]	2.32 [58,9]	2.59 [65,8]	2.84 [72,1]	3.09 [78,5]	3.34 [84,8]	3.83 [97,3]	
	'L'	1.75 [44,5]	1.74 [44,2]	1.75 [44,3]	1.76 [44,6]	1.76 [44,6]	1.78 [45,2]	1.80 [45,7]	
	'M'	0.70 [17,8]	0.89 [22,6]	1.17 [29,7]	1.36 [34,6]	1.53 [38,9]	1.67 [42,4]	2.11 [53,6]	
1.00 [DN25]	'A'		6.12 [155,4]	8.50 [215,9]	11.00 [279,4]	12.50 [317,5]	14.00 [355,6]	17.00 [431,8]	
	'B'		3.00 [76,2]	3.75 [95,2]	4.75 [120,6]	5.50 [139,7]	6.25 [158,8]	8.00 [203,2]	
	'C'		3.63 [92,2]	3.90 [99,1]	4.16 [105,7]	4.42 [112,3]	4.68 [118,9]	5.19 [131,8]	
	'D'		1.50 [38,1]	1.50 [38,1]	1.50 [38,1]	1.50 [38,1]	1.50 [38,1]	1.50 [38,1]	
	'E'		0.28 [7,1]	0.59 [15,0]	0.81 [20,6]	0.98 [24,9]	1.15 [29,2]	1.44 [36,6]	
	'F'		3.25 [82,6]	3.52 [89,4]	3.78 [96,0]	4.04 [102,6]	4.30 [109,2]	4.81 [122,2]	
	'H'		1.12 [28,4]	1.12 [28,4]	1.12 [28,4]	1.12 [28,4]	1.12 [28,4]	1.12 [28,4]	
	'J'		0.63 [16,0]	0.88 [22,4]	0.65 [16,5]	0.92 [23,4]	1.24 [31,5]	1.73 [43,9]	
	'K'		2.52 [64,0]	2.78 [70,6]	3.05 [77,5]	3.31 [84,1]	3.56 [90,4]	4.05 [102,9]	
	'L'		1.99 [50,5]	2.00 [50,8]	1.99 [50,5]	1.99 [50,5]	2.00 [50,8]	2.02 [51,3]	
	'M'		0.96 [24,4]	1.26 [32,0]	1.48 [37,6]	1.65 [41,9]	1.82 [46,2]	2.11 [53,6]	
1.50 [DN40]	'A'			8.50 [215,9]	11.00 [279,4]	12.50 [317,5]	14.00 [355,6]	17.00 [431,8]	
	'B'			3.75 [95,2]	4.75 [120,6]	5.50 [139,7]	6.25 [158,8]	8.00 [203,2]	
	'C'			4.46 [113,3]	4.73 [120,1]	4.99 [126,7]	5.25 [133,4]	5.76 [146,3]	
	'D'			1.50 [38,1]	1.50 [38,1]	1.50 [38,1]	1.50 [38,1]	1.50 [38,1]	
	'E'			0.23 [5,8]	0.55 [13,9]	0.79 [20,1]	0.99 [25,1]	1.32 [33,5]	
	'F'			4.08 [103,6]	4.35 [110,5]	4.61 [117,1]	4.87 [123,7]	5.38 [136,7]	
	'H'			1.12 [28,4]	1.12 [28,4]	1.12 [28,4]	1.12 [28,4]	1.12 [28,4]	
	'J'			0.75 [19,0]	0.88 [22,4]	0.88 [22,4]	0.99 [25,1]	1.28 [32,5]	
	'K'			3.35 [85,1]	3.63 [92,2]	3.90 [99,1]	4.16 [105,7]	4.66 [118,4]	
	'L'			2.54 [64,5]	2.54 [64,5]	2.53 [64,3]	2.53 [64,3]	2.54 [64,5]	
	'M'			1.26 [32,0]	1.58 [40,1]	1.82 [46,2]	2.02 [51,3]	2.35 [59,7]	
2.00 [DN50]	'A'				11.00 [279,4]	12.50 [317,5]	14.00 [355,6]	17.00 [431,8]	
	'B'				4.75 [120,6]	5.50 [139,7]	6.25 [158,8]	8.00 [203,2]	
	'C'				5.28 [134,1]	5.55 [141,0]	5.82 [147,8]	6.32 [160,5]	
	'D'				1.75 [44,4]	1.75 [44,4]	1.75 [44,4]	1.75 [44,4]	
	'E'				0.28 [7,1]	0.59 [15,0]	0.83 [21,1]	1.21 [30,7]	
	'F'				4.66 [118,4]	4.93 [125,2]	5.19 [131,8]	5.70 [144,8]	
	'H'				1.12 [28,4]	1.12 [28,4]	1.12 [28,4]	1.12 [28,4]	
	'J'				0.97 [24,6]	1.00 [25,4]	1.03 [26,2]	1.01 [25,7]	
	'K'				3.93 [99,8]	4.20 [106,7]	4.47 [113,5]	4.99 [126,7]	
	'L'				3.05 [77,5]	3.04 [77,2]	3.03 [77,0]	3.02 [76,7]	
	'M'				1.60 [40,6]	1.92 [48,8]	2.15 [54,6]	2.54 [64,5]	

NOTES:
 1. LEFT HAND AND RIGHT HAND ORIENTATION IS DETERMINED BY VIEWING THE MACHINE FACE OF THE MAIN VALVE.

LIST OF MAJOR COMPONENTS			
ITEM	DESCRIPTION	MATERIAL	QTY
1	BODY-ZSBBS	SS 316L	1
2	TUBING-ELBOW 90° CROSS TUBE END G16	SS 316L	AR
3	TUBING-VALVE END 16G	SS 316L	1
4	FERRULE-CROSS TUBE END TC	SS 316L	AR
5	FERRULE-VALVE END TC	SS 316L	1
6	STUD		4
7	FERRULE-SAMPLE PORT END TC 00.50 x 01.12	SS 316L	1
	FERRULE-REDUCING SAMPLE PORT END TC 00.50 x 01.12	SS 316L	1

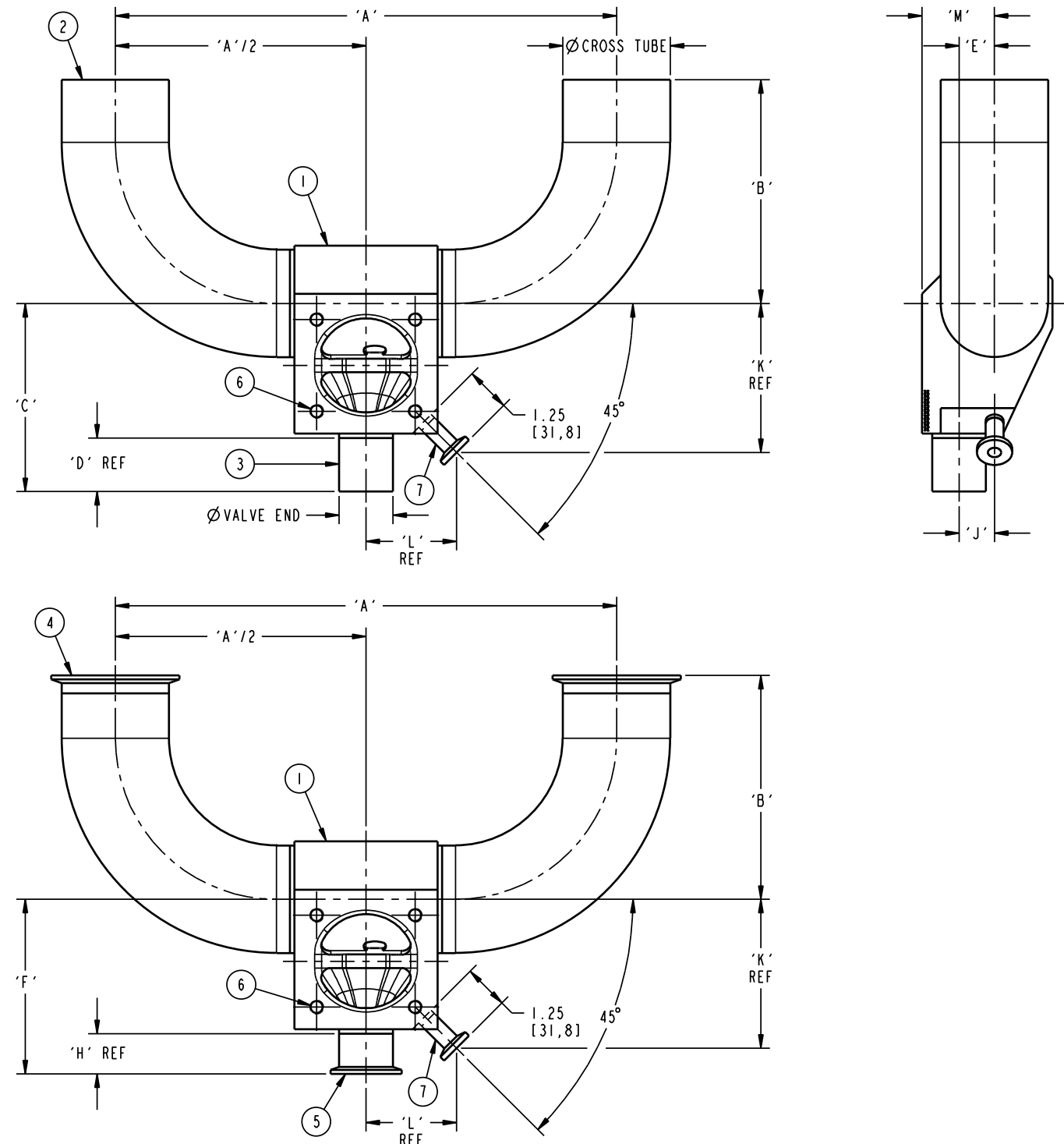

RIGHT HAND ORIENTATION SHOWN
 SEE NOTE 1

	PURE-FLO ORDER: -	ITEM: -	THIS DOCUMENT IS THE SOLE PROPERTY OF ITT INDUSTRIES, INC., OR ITS SUBSIDIARY, AND IS PROVIDED SUBJECT TO RETURN. IT IS ISSUED IN STRICT CONFIDENCE AND SHALL NOT BE REPRODUCED, OR COPIED, OR DISCLOSED IN WHOLE OR IN PART, OR USED AS THE BASIS FOR THE MANUFACTURE OR SALES OF APPARATUS OR PARTS TO WHICH THE DOCUMENT RELATES, WITHOUT THE EXPRESS WRITTEN CONSENT OF ITT INDUSTRIES, INC., OR ITS SUBSIDIARY. THIS LEGEND SHALL BE MARKED ON ANY REPRODUCTION HEREOF, IN WHOLE OR IN PART. ALL RIGHTS TO THE INFORMATION AND DESIGN DISCLOSED HEREIN ARE RESERVED TO ITT INDUSTRIES, INC., OR ITS SUBSIDIARY.	THIRD ANGLE PROJECTION	UNLESS OTHERWISE NOTED	DATE	BY	STANDARDS-ZSBBS U-BENDS	
	CUSTOMER PO: -			INCH	MM	01/26/05	JWP	WEIR 00.75 - 02.00	
	CUSTOMER PO: -					01/28/05	JRD	VERTICAL RUN x VERTICAL VALVE	
	OTHER INFO: -					01/28/05	JRD	WT: -	
	ISSUED BY: -	CERTIFIED BY: -						ECN# 8555	MASTER DWG
									SITE PA
									D
									008883
									SHEET 1 OF 1